



TP-LD53

User Manual

Version 4.0

www.solaxpower.com



STATEMENT

Copyright

Copyright © SolaX Power Network Technology (Zhejiang) Co., Ltd. All rights reserved.

No part of this manual may be reproduced, transmitted, transcribed, stored in a retrieval system, or translated into any language or computer language, in any form or by any means without the prior written permission of SolaX Power Network Technology (Zhejiang) Co., Ltd.

Trademarks



POWER and other symbol or design (brand name, logo) that distinguishes the products or services offered by SolaX has been trademark protected. Any unauthorized use of above stated trademark may infringe the trademark right.

Notice

All or part(s) of the products, features and services described in this document may not be within your scope of purchase or usage. Unless otherwise specified in the contract, the contents, information and recommendations in this document are provided as is, SolaX makes no kind of warranties, guarantees or representations expressly or implicitly.

The content of the documents is continually reviewed and amended, where necessary. However, discrepancies cannot be excluded. SolaX reserves the right to make improvements or changes in the product(s) and the program(s) described in this manual at any time without the prior notice.

The images contained in this document are for illustrative purposes only and may vary depending on product models.

Please visit the website www.solaxpower.com of SolaX Power Network Technology (Zhejiang) Co., Ltd. for more information.

SolaX reserves all the right for the final explanation.

About This Manual

Scope of Validity

This manual is an integral part of T-BAT Series. It describes the installation, electrical connection, commissioning, maintenance and troubleshooting of the product. Please read it carefully before operating.

Battery pack
TP-LD53

Note:

In the case of floor mounting, it contains battery pack(s) only. In the case of wall mounting, it contains battery pack(s) and wall bracket(s). For details, please refer to the Chapter 13 [“Technical Data”](#).





Target Group

The installation and maintenance can only be performed by qualified personnel who

- Are licensed and/or satisfy state and local jurisdiction regulations.
- Have good knowledge of this manual and other related documents.

Conventions

The symbols that may be found in this manual are defined as follows.

Symbol	Description
 DANGER	Indicates a hazardous situation which, if not avoided, will result in death or serious injury.
 WARNING	Indicates a hazardous situation which, if not avoided, could result in death or serious injury.
 CAUTION!	Indicates a hazardous situation which, if not avoided, could result in minor or moderate injury.
 NOTICE!	Provides tips for the optimal operation of the product.

Change History

Version 04 (2025-2-18)

Updated "[1.3 Battery Handling Guide](#)" (Added prohibition of using battery in lead-acid mode)

Updated "[5.2 Scope of Delivery](#)" (Altered part C communication cable)

Updated "[5.2 Scope of Delivery](#)" and "[6.2.2 Wall Mounting](#)" (Added circle drawing board and deleted waterproof plug)

Updated "[7 Wiring](#)" (Deleted the step of covering waterproof plug)

Added "[8 Parallel Connection](#)"

Added "[9 Connection to the Third-party Inverter](#)"

Updated "[11.1 Troubleshooting](#)" (Altered error code)

Updated "[Contact Information](#)" (Altered the Australia e-mail)

Version 03 (2024-08-05)

Updated "[1.3 Battery Handling Guide](#)" (Deleted "DON'T store or install the battery module in direct sunlight")

Updated "[4.1.1 Environment Requirement](#)"

Updated "[Back Cover](#)" (Deleted the company website)

Updated temperature (Altered 302°F/60°C to 302°F/150°C)

Updated warranty claim (Deleted 120 months warranty claim)

Version 02 (2024-05-07)

Updated "[5.2 Scope of Delivery](#)"

Updated "[9.2 Powering On/Off the System](#)" (Added a matter to be noted)

Version 01 (2024-01-18)

Updated "[6 Mechanical Installation](#)" (Altered torque information)

Version 00 (2023-10-20)

Initial Release

Table of Contents

- 1 Safety 1
 - 1.1 General Safety 1
 - 1.2 General Safety Precautions 2
 - 1.3 Battery Handling Guide..... 2
 - 1.4 Response to Emergency Situations..... 3
- 2 Product Overview 5
 - 2.1 System Description 5
 - 2.2 Appearance, Weight and Dimensions 5
 - 2.2.1 Label..... 7
 - 2.2.2 Electrical Connection Area 8
 - 2.2.3 Indicator Panel 11
 - 2.3 Symbols on the Label..... 15
 - 2.4 Features 16
 - 2.5 Certifications..... 16
- 3 Transportation and Storage 17
- 4 Preparation before Installation..... 19
 - 4.1 Selection of Installation Location 19
 - 4.1.1 Environment Requirement 19
 - 4.1.2 Installation Carrier Requirement..... 20
 - 4.1.3 Clearance Requirement 21
 - 4.2 Tools Requirement..... 23
 - 4.3 Additionally Required Materials 23
- 5 Unpacking and Inspection 24
 - 5.1 Unpacking..... 24
 - 5.2 Scope of Delivery..... 25
- 6 Mechanical Installation 28
 - 6.1 Installation Options..... 28
 - 6.2 Installation Procedure 29
 - 6.2.1 Floor Mounting 30
 - 6.2.2 Wall Mounting 35
- 7 Wiring..... 44
 - 7.1 Details of Cables 44
 - 7.2 PE Connection 45

7.3	Communication Connection.....	47
7.4	Ring Terminal Installation.....	48
7.5	Female Connector Installation.....	49
7.6	Wiring Procedure.....	53
7.6.1	The Right Electrical Connection Area of the Battery pack Selected to Be Connected to the Inverter.....	53
7.6.2	The Left Electrical Connection Area of the Battery pack Selected to Be Connected to the Inverter.....	58
8	Parallel Connection.....	64
8.1	Wiring of Parallel Connection.....	64
8.2	Materials Requirement.....	65
9	Connection to the Third-party Inverter.....	66
9.1	Cable Connection.....	66
9.1.1	Connection of Capacity Expansion.....	66
9.1.2	Connection of Power Expansion.....	67
9.2	Powering-on of the Third-party Inverter.....	68
10	System Commissioning.....	69
10.1	Checking before Power-on.....	69
10.2	Powering on/off the System.....	69
11	Troubleshooting and Maintenance.....	71
11.1	Troubleshooting.....	71
11.2	Maintenance.....	75
12	Decommissioning.....	76
12.1	Disassembling the Battery.....	76
12.2	Packing.....	78
12.3	Disposing of the Rechargeable Battery.....	78
13	Technical Data.....	79

1 Safety

1.1 General Safety

The series rechargeable battery is well designed and tested to meet all applicable states and international safety standards. However, like all electrical and electronic equipment, safety precautions must be observed and followed during the installation of the rechargeable battery to reduce the risk of personal injury and to ensure a safe installation.

Before installing the device, carefully read, fully understand and strictly follow the detailed instruction of the *User Manual* and other related regulations. And the safety instructions in this document are only supplements to local laws and regulations.

SolaX shall not be liable for any consequences caused by the violation of the storage, transportation, installation, and operation regulations specified in this document, including, but not limited to:

- Rechargeable battery damage due to force majeure, such as earthquake, flooding, thunderstorm, lighting, fire hazard, volcanic eruption, overvoltage, etc.
- Rechargeable battery damage due to man-made cause
- Rechargeable battery used or operated against any items in local policy
- Failure to follow the operation instructions and safety precautions on the product and in this document
- Installation and use under improper environment or electrical condition
- Unauthorized modifications to the product or software
- Rechargeable battery damage caused during transportation by the customer
- Storage conditions that do not meet the requirements specified in this document
- Failure to adequately maintain the equipment.
- Use of incompatible inverters or devices
- Installation and commissioning operated by unauthorized personnel who are not licensed and /or satisfy state and local jurisdiction regulations.

1.2 General Safety Precautions

- Overvoltage or wrong wiring may damage the battery pack and cause combustion which may be extremely dangerous;
- Leakage of electrolytes or flammable gas may be occurred due to any type of product breakdown;
- Do not install the battery pack in places where flammable and combustible materials are stored, and in which an explosive atmosphere is present;
- The battery pack wiring must be carried out by qualified personnel;
- Battery pack must be serviced by qualified personal;
- Ensure that the grounding cable is connected before handling the battery pack.

1.3 Battery Handling Guide

Do's

- DO keep the battery pack away from flammables materials, heat sources, and water sources;
- DO keep the battery pack out of reach of children and animals;
- DO practice proper battery storage by keeping the battery pack in a clean environment, free of dust, dirt and debris;
- DO store the battery pack in a cool and dry place;
- DO seal the outer cable connection hole to prevent ingress of foreign objects;
- DO confirm that the wiring of the device must be correct;
- DO install the device according to the local standards and regulations.

Don'ts

- DON'T use SolaX lithium battery in Lead-acid mode. Lead-acid mode not only reduce the lifespan of lithium batteries, but may also cause safety issues under extreme conditions. Any consequences arising from the use of lead-acid mode shall be borne by users themselves, and SolaX will not provide warranty!
- DON'T expose the battery pack to an open flame, or the temperature in excess of 140°F/60°C;
- DON'T install or operate the battery pack in places where there is excessive moisture or liquids;
- DON'T place the battery pack in a high-voltage environment;
- DON'T disconnect, disassemble or repair the device by unqualified personnel. Only a qualified personnel is allowed to handle, install and repair the device;

- DON'T damage the device by dropping, deforming, impacting, cutting or penetrating with a sharp object. Otherwise, it may cause a fire or leakage of electrolytes;
- DON'T touch the device if liquid spill on it. There is a risk of electric shock;
- DON'T step on the packaging or the device may be damaged;
- DON'T place any objects on top of the battery pack;
- DON'T charge or discharge a damaged battery pack;
- DON'T dispose of the battery pack in a fire. It may cause leakage or rupture;
- DON'T mix different types or makes of the battery pack. It may cause leakage or rupture, resulting in personal injury or property damage.

1.4 Response to Emergency Situations

In case the battery pack leaks electrolyte or any other chemical materials, or gas may be generated due to the leakage of battery pack, be sure to avoid contact with the discharge at all times. In case of accidentally coming into contact with them, please do as follows:

- In case of inhalation: Leave the contaminated area immediately, and seek medical attention at once;
- In case of contact with eyes: Rinse eyes with running water for 15 minutes, and seek medical attention;
- In case of contact with skin: Wash the contacted area thoroughly with soap, and seek medical attention;
- In case of ingestion: Induce vomiting, and seek medical attention.

If a fire breaks out where the battery pack is installed, please do as follows:

- In case the battery pack is charging when the fire breaks out, provide it is safe to do so, disconnect the battery pack circuit break to shut off the power charge;
- In case the device is not on fire yet, use a Class ABC fire extinguisher or a carbon dioxide extinguisher to extinguish the fire;
- If the battery pack catches fire, do not try to put out the fire, and evacuate immediately.
- The battery pack may catch fire when it is heated above 302°F/150°C; and in case of catching fire, it will produce noxious and poisonous gas, DO not approach and keep away.

Effective ways to deal with accidents

- In case of the damaged battery pack, place it into a segregated place, and call the local fire department at the place where the user lives or qualified personnel.
- If any part of the battery pack, or wiring is submerged, DO stay out of the water and DON'T touch anything; If the battery pack gets wet, DON'T touch it.
- If the battery pack is damaged, DON'T use it. Otherwise, it may result in both personal injury and property damage.
- DON'T use the submerged battery pack again, and contact the qualified personnel for assistance.
- DO contact SolaX immediately for assistance if the user suspects that the battery pack is damaged.

WARNING!

- Do not crush or impact battery, and always dispose of it according to relevant safety regulations.
- The battery pack may catch fire when heated above 150°C/302°F.
- In case of catching fire, the battery pack will produce noxious and poisonous gases, and please keep away the battery.
- Damaged batteries may leak electrolyte or produce flammable gas. If users suspect that the battery is damaged, please immediately contact SolaX for advice and information.
- All operations of T-BAT-SYS-LD relating to electrical connection and installation must be carried out by qualified personnel.

CAUTION!

- If the battery pack is not installed within a month after receipt, it must be charged for maintenance. Non-operational batteries should be discarded according to the local regulations.

2 Product Overview

⚠ WARNING!

- The bi-directional energy storage inverter connected with the battery pack must be an isolated inverter.

2.1 System Description

The battery system consists of one or more rechargeable batteries. A battery pack is a type of electrical battery which can charge or discharge loads.

There are two installation options, such as floor mounting and wall mounting, that a user can select from.

2.2 Appearance, Weight and Dimensions

Appearance

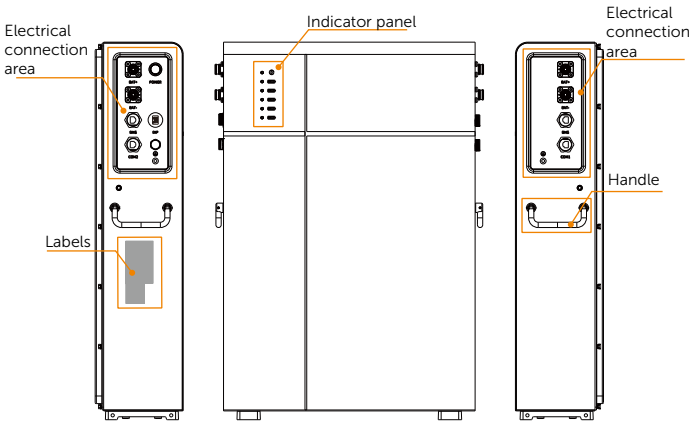

Figure 2-1 Appearance

Table 2-1 Description of appearance

Item	Description
"Label"	Including performance label, which clearly identifies the device type, serial number, parameters, certification, etc., and manufacturer label describing name and address of manufacturer.
Electrical connection area	Including BAT+/BAT- ports, communication port, BMS port, grounding port, DIP, and POWER button. Please refer to "Electrical Connection Area" for details.
Indicator panel	Provide a human-readable indication of an instrument signal. For details, please refer to "Indicator Panel" .
Handle	Lift the battery conveniently.

Weight and Dimensions

Table 2-2 Weight and dimensions of a battery pack

	Battery pack (TP-LD53)
Length (mm)	430
Width (mm)	150
Height (mm)	645
Net weight (kg)	48

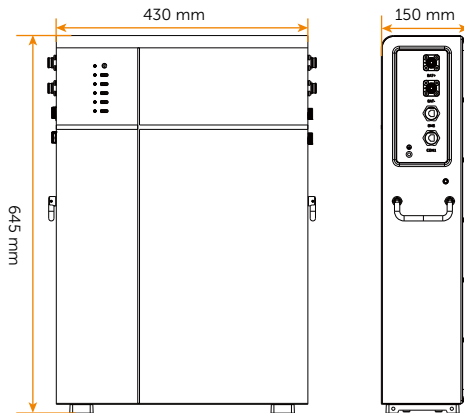

Figure 2-2 Dimension: Battery pack (TP-LD53)

2.2.1 Label

Some kinds of labels, such as a performance label, a manufacturer label, etc., should be pasted on the battery pack. The above-mentioned labels are located on the right side of the battery pack. For example, the performance label consists of the following parts:

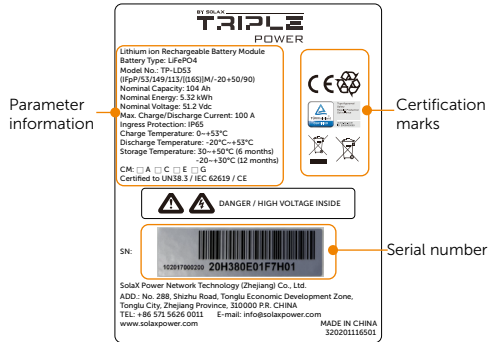
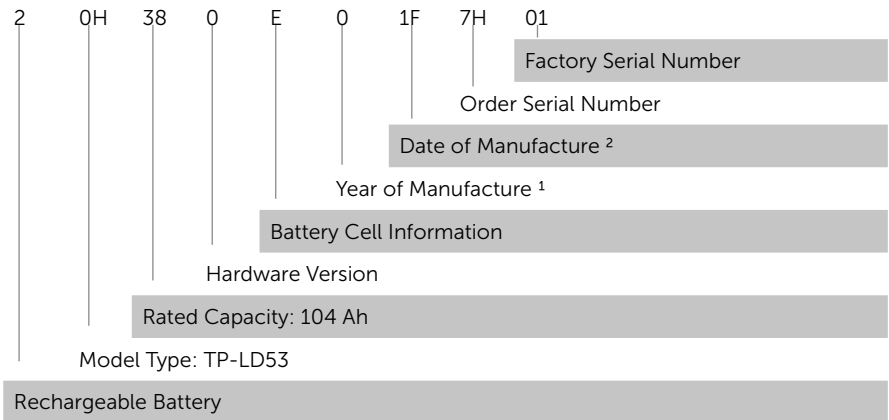

Figure 2-3 Label

Regarding the **SN**, 32-base nomenclature is adopted to identify the type, specific features, manufacture date, order serial number, and factory serial number of a battery pack.

32-base Nomenclature



¹ 0-2023, 1-2024, 2-2025 A-2033, B-2034

² The two digits represent the week of when the battery pack was produced. There are totalling 52 weeks in a year, and the first week is represented by the number 00, and the second week is represented by the number 01. Do the rest in the same manner in accordance with the 32-base coding rule.

2.2.2 Electrical Connection Area

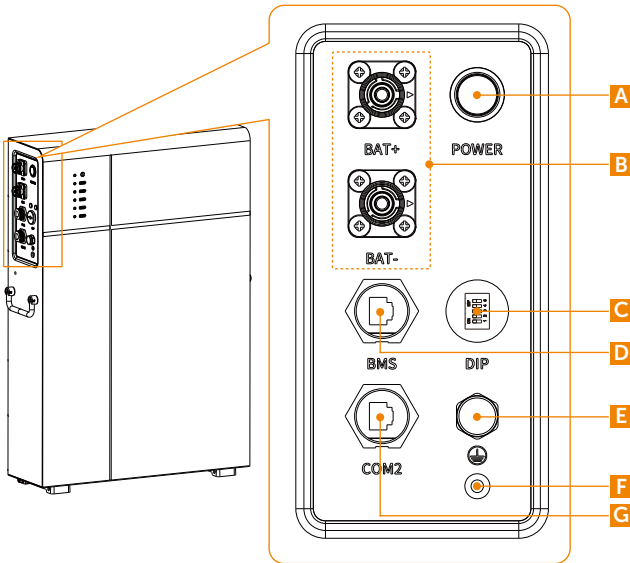

Figure 2-4 Right side of battery pack

Table 2-3 Description of ports and keys

Item	Description
A	Power button: Start/shut down system.
B	BAT+/BAT- port: Connect to the BAT+/BAT- port of the inverter or the adjacent battery pack.
C	"DIP Switch" : Realize battery's parallel function (a reserved function).
D	"BMS" port: Connect to the "BMS" port on the inverter. Or, it shall be covered by a waterproof plug if it is not connected.
E	Breather valve: To balance the pressure differentials inside and outside a battery pack.
F	Grounding port: Connect to the grounding port of the battery pack or BMS.
G	COM2 port: Connect to the COM1 port of the neighbouring battery pack (if any). Or, it shall be covered by a waterproof cap if it is not connected.

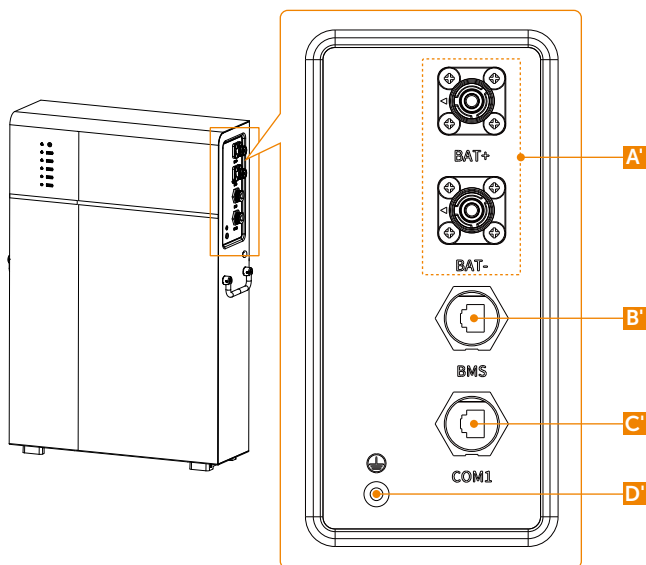

Figure 2-5 Left side of battery pack

Table 2-4 Description of ports

Item	Description
A'	BAT+/BAT- port: Connect to the BAT+/BAT- port of the inverter or the adjacent battery pack
B'	"BMS" port: Connect to the "BMS" port of the inverter, or it doesn't need to be connected. Or, it shall be covered by a waterproof plug if it is not connected.
C'	COM1 port: Connect to the COM2 port of the adjacent battery pack (if any). Or, it shall be covered by a waterproof cap if it is not connected.
D'	Grounding port: Connect to the grounding port of the neighbouring battery pack.

DIP Switch

A DIP Switch is actually a set of small manual electronic switches that are designed to be packaged with other circuits. It is currently equipped with the battery pack.

The location of the DIP switch and the factory defaults are shown as below.

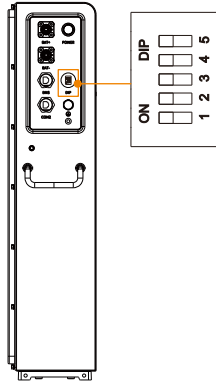

Figure 2-6 DIP Switch

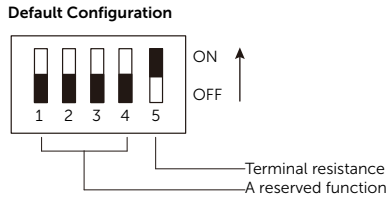

Figure 2-7 Default configuration

NOTICE!

- In the case of one tower, there is only one master battery pack (always the uppermost battery pack). While the master battery pack connects to the inverter, **please confirm that the DIP switch 5 must stay in the ON position**, as well as the DIP switch 5 on the rest of the battery packs in the ON positions. Usually, the DIP switch 5 will be slid to the ON position in the factory settings.
- In the case of more than two towers, except that the master battery pack (always the uppermost battery pack) of the last tower shall be slid to the ON position, the Dip switch 5 on the rest of the master battery packs shall be flipped up to the OFF positions. Regarding the Dip switch 5 on the rest of the battery packs, please confirm that they are in the ON positions. Usually, the DIP switch 5 will be slid to the ON position in the factory settings.
- To adjust the DIP switch, a small flat-head screwdriver should be prepared by the users themselves. **Do not use a pencil.** Graphite from the pencil is conductive and may damage the DIP switch.

2.2.3 Indicator Panel

The battery pack is equipped with a monochrome status light (blue) and five tri-colour SOC power indicators (green/yellow/red) to show its operating status. The SOC power indicators show the current battery percentage.

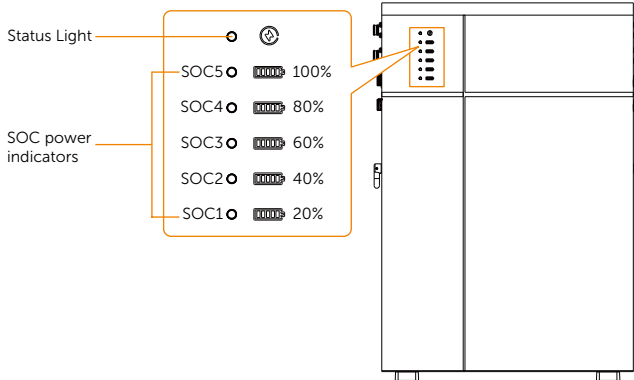

Figure 2-8 Indicators

Table 2-5 Description of indication

LED	Colour	State	Indication
Status light	Green	Flashing	Start up
SOC power indicators	Blue	Solid	
Status light	Yellow	Solid → Off	Shut down
SOC power indicators	Blue	Solid → Off	
Status light	Green	Solid	Standby
SOC power indicators	Blue	Solid	
Status light	Green	Flashing	Charging
SOC power indicators	Please refer to " Indicator information while charging ".		
Status light	Green	Flashing	Discharging
SOC power indicators	Please refer to " Indicator information while discharging ".		
Status light	Red	Flashing	Fault
SOC power indicators	Blue	Solid	

Status light _____ Please refer to [“Black Start”](#). Black Start
 SOC power indicators _____

NOTICE!

- The function of **Self Test** will be performed when users turn the system on, with a duration of 11 seconds. In the meantime, the status light will remain on solid yellow light, and the SOC power indicators will remain on solid blue light based on their actual remaining capacity.

Table 2-6 Indicator information while charging

SOC value	Status light	SOC1	SOC2	SOC3	SOC4	SOC5
LED colour	Green	Blue	Blue	Blue	Blue	Blue
0% = SOC	Flashing	Light off	Light off	Light off	Light off	Light off
0% < SOC < 20%	Flashing	Flash	Light off	Light off	Light off	Light off
20% ≤ SOC < 40%	Flashing	Flash	Flash	Light off	Light off	Light off
40% ≤ SOC < 60%	Flashing	Flash	Flash	Flash	Light off	Light off
60% ≤ SOC < 80%	Flashing	Flash	Flash	Flash	Flash	Light off
80% ≤ SOC ≤ 100%	Flashing	Flash	Flash	Flash	Flash	Flash

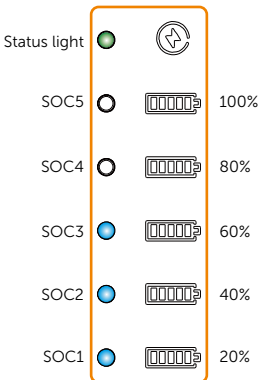

If the battery level is at 60%, the SOC power indicators will show as follows:

- The first three SOC power indicators (SOC1, SOC2 and SOC3) will flash blue light every 1 second;
- The remaining SOC power indicators (SOC4 and SOC5) will be off.

Figure 2-9 Charging

NOTICE!

- When the charging current is less than or equal to 1 A, the SOC indicators will remain on solid blue light.
- When the charging current is over 1 A, the SOC indicators will flash blue lights.

If more than two battery packs (including two) are purchased, the circumstance that some of the battery packs' SOC indicators may flash blue and the remaining battery packs' SOC indicators may remain on solid blue, may occur. The reasons for this circumstance are as follows:

- If the battery packs are charged fully, the SOC indicators will remain on solid blue light.
- If the battery packs are not charged fully, it indicates that the charging current is less than or equal to 1 A.

Table 2-7 Indicator information while discharging

SOC value	Status light	SOC1	SOC2	SOC3	SOC4	SOC5
LED colour	Green	Blue	Blue	Blue	Blue	Blue
SOC \geq 80%	Flashing	Light on	Light on	Light on	Light on	Light on
SOC \geq 60%	Flashing	Light on	Light on	Light on	Light on	Light off
SOC \geq 40%	Flashing	Light on	Light on	Light on	Light off	Light off
SOC \geq 20%	Flashing	Light on	Light on	Light off	Light off	Light off
SOC > 0%	Flashing	Light on	Light off	Light off	Light off	Light off
SOC = 0%	Flashing	Light off	Light off	Light off	Light off	Light off

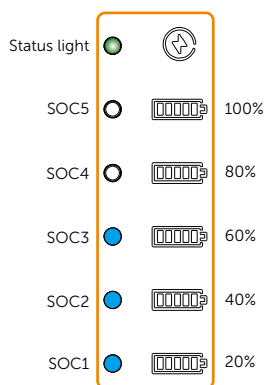

If the battery level is at 60%, the SOC power indicators will show as follows:

- The first three SOC power indicators (SOC1, SOC2, and SOC3) will remain on solid blue light;
- The remaining SOC power indicators (SOC4 and SOC5) will be off.

Figure 2-10 Discharging





Black Start

The equipment can provide **Black Start** capacity, meaning that our energy storage inverter and battery can continue to run even if the power grid and photovoltaic panel are out of service. The startup procedure for **Black Start** is as follows:

- First stage: in case of pressing and holding the **POWER** button for less than 15 seconds, the status light will come on solid yellow light in the first 11 seconds and then turn to solid green light in the last 4 seconds, and the SOC power indicators will come on solid blue light based on the actual remaining capacity.
- Second stage: after pressing and holding the **POWER** button for more than 15 seconds, the status light will flash yellow light every 1 second, and all the SOC power indicators will remain on solid blue light based on the actual remaining capacity.
- Finally, release the **POWER** button.

2.3 Symbols on the Label

Table 2-8 Description of symbols

Symbol	Description
	CE mark. The rechargeable battery complies with the requirements of the applicable CE guidelines.
	TUV certified.
	The battery system must be disposed of at a proper facility for environmentally-safe recycling.
	The battery pack may explode. The rechargeable battery can become hot during operation. Avoid contact during operation.
	Danger of high voltages. Danger to life due to high voltages in the rechargeable battery!
	Danger. Risk of electric shock!
	Observe enclosed documentation.
	The rechargeable can not be disposed together with the household waste.
	The rechargeable can not be disposed together with the household waste.
	Keep the battery system away from children.
	Keep the battery system away from open flames or ignition sources.

2.4 Features

The T-BAT-SYS-LD is one of the most advanced energy storage systems on the market today, using state-of-the-art technology, and having the characteristics of high reliability and convenient control. Characteristics are shown as follows:

- 90% DOD;
- 95% Battery Round-trip Efficiency;
- Cycle Life > 6000 Cycles;
- Secondary Protection;
- IP65 Protection Level and Protection Class I;
- Safety & Reliability;
- Small Occupied Area;
- Floor Mounting and wall mounting.

2.5 Certifications

BAT system safety	CE, IEC 62619, IEC 63056, IEC 62620, IEC 62477-1, IEC 60730 Annex H, IEC 60529, UN38.3
UN number	UN 3480
Hazardous materials classification	Class 9
UN transportation testing requirements	UN 38.3
International protection marking	IP65, Protection Class I

3 Transportation and Storage

If the rechargeable battery are not put into use immediately, the transportation and storage requirements needs to be met:

Transportation

- Observe the caution signs on the packaging of battery before transportation.
- Pay attention to the weight of the rechargeable battery. Be cautious to avoid injury when carrying battery pack (TP-LD53). Regarding the actual number of installers, please strictly comply with the local laws and regulations where the user is located.
- Wear protective gloves when carrying the equipment by hand to prevent injuries.
- When lifting up the rechargeable battery, hold the handle position and the bottom position of the battery. Keep the rechargeable battery horizontal in case of falling down due to tilt.

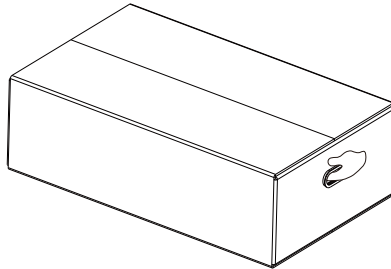

Figure 3-1 Handle position of carton

Storage

- Do not remove the original packaging material and check the outer packaging material regularly.
- The required storage temperature: the service life may be up to 6 months in case the temperature is between 30°C and +50°C, or it may be up to 12 months in case the temperature is between -20°C and +30°C. See Table 3-1. Regarding charging interval, please refer to Chapter 11.2 "[Maintenance](#)".

Table 3-1 Storage temperature and time

Storage Temperature	Storage Time
30°C to 50°C	6 months
-20°C to 30°C	12 months

- The relative humidity should be between 5% and 95%.
- Stack the battery in accordance with the caution signs on the battery carton to prevent their falling down and device damage. Do not place it upside down.
- If the rechargeable battery has been stored for more than 1 year, it must be checked and tested by professionals before use.

4 Preparation before Installation

4.1 Selection of Installation Location

The installation location selected for the rechargeable battery is quite critical in the aspect of the guarantee of machine safety, service life and performance.

- It has the IP65 ingress protection, which allows it to be installed outdoor;
- Before installing the battery system, lay out available floor space or wall space including aisles for installation, maintenance and possible battery pack replacement.

4.1.1 Environment Requirement

Make sure the installation site meets the following conditions:

- The operating temperature: -20°C to $+53^{\circ}\text{C}$;
- The humidity shall be between 5-95%;
- Do not install the rechargeable battery in the areas where the altitude exceeds 3000 m;
- Install the rechargeable battery in a well-ventilated environment for heat dissipation;
- Do not install the rechargeable battery in areas with flammable, explosive and corrosive materials;
- Do not install the rechargeable battery in areas near combustibles and antenna
- You are recommended to install an awning over it.

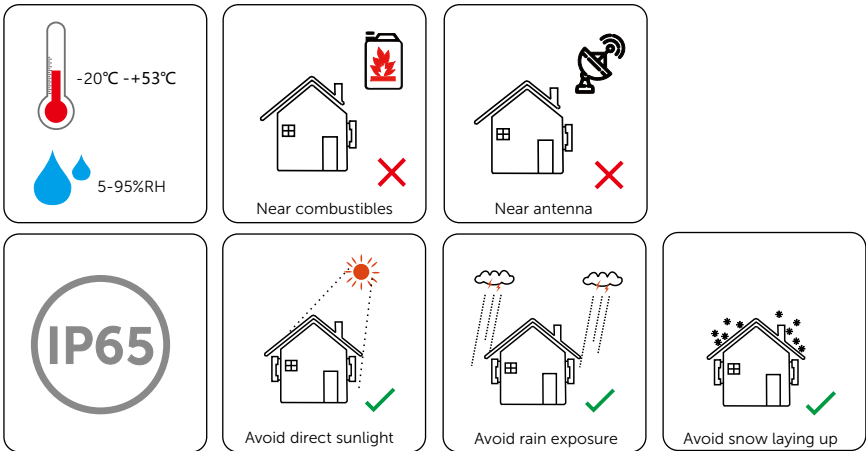

NOTICE!

- For outdoor installation, precautions against direct sunlight, rain exposure and snow laying up are recommended.
- Exposure to direct sunlight raises the temperature inside the battery. This temperature rise poses no safety risks, but may impact the battery performance.

4.1.2 Installation Carrier Requirement

The mounting location must be suitable for the weight and dimensions of the product and the support surface for installation must be made of a non-flammable material.

- Solid brick/concrete;
- Either floor mounting or wall mounting, the bearing capacity of the area to place or install a battery pack must be over 200 kg;
- Please ensure that the thickness of any part of the wall should not be less than 100 mm;
- The device must not be installed on the wood wall.

4.1.3 Clearance Requirement

To guarantee proper heat dissipation and ease of disassembly, the minimum space around the rechargeable battery must meet the standards indicated below.

- No matter which floor mounting or wall mounting is chosen, a distance between 200 and 300 mm wide shall be provided from the wall to the edge of the battery pack.
- No matter which floor mounting or wall mounting is chosen, a distance between 400 and 600 mm wide shall be provided from the left side edge of a battery pack to the right side edge of the neighbouring battery packs.
- In the case of floor mounting, a distance of 55 mm shall be provided from the rear side of the battery pack to the wall.
- In the case of wall mounting, the distance between 300 and 350 mm shall be provided from the grounding to the bottom of the battery pack.

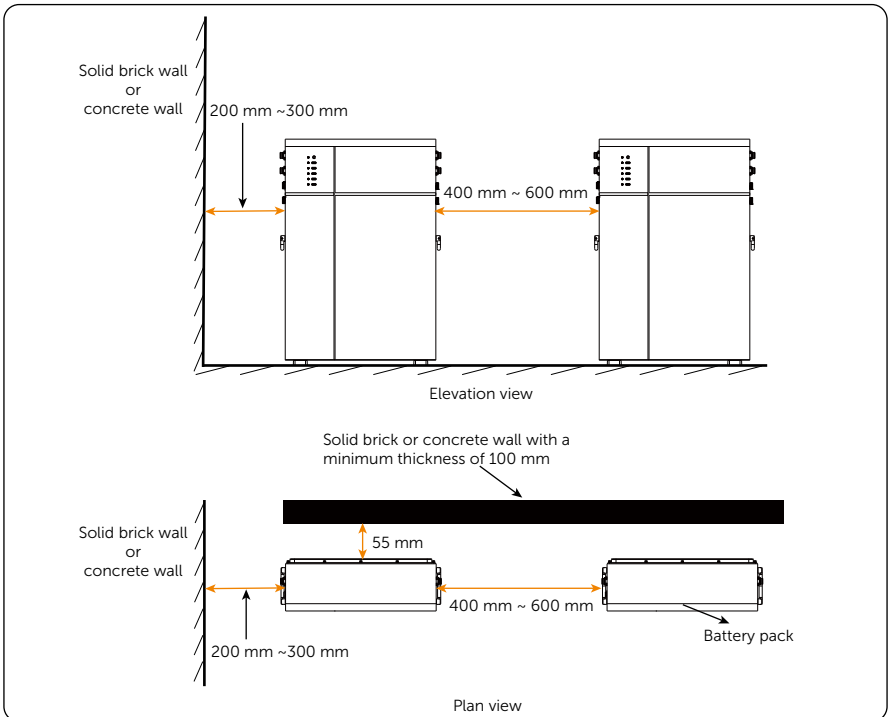

Figure 4-2 Clearance requirement about floor mounting

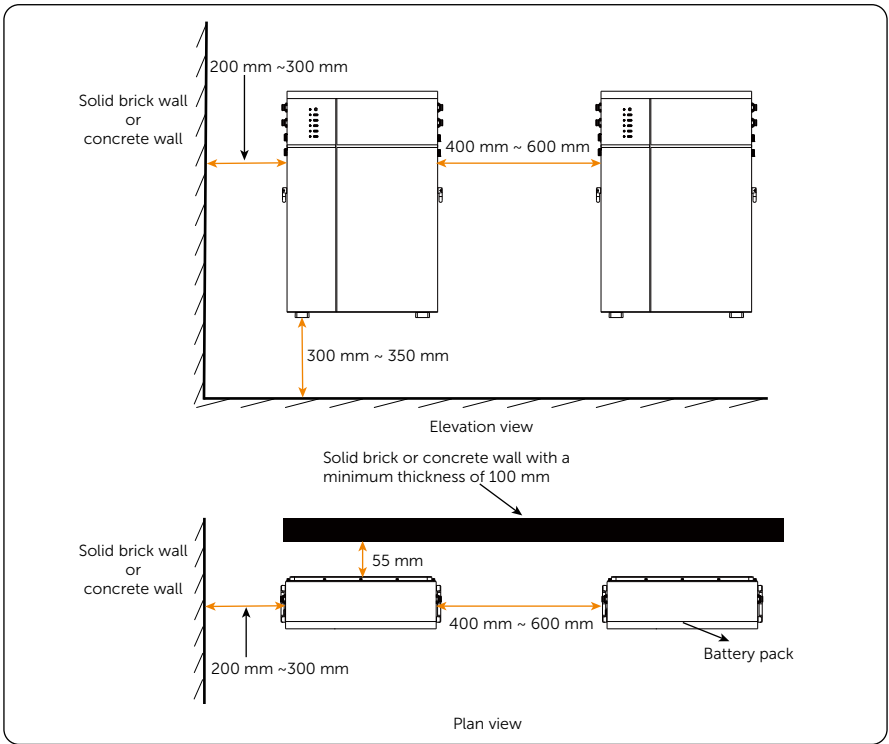
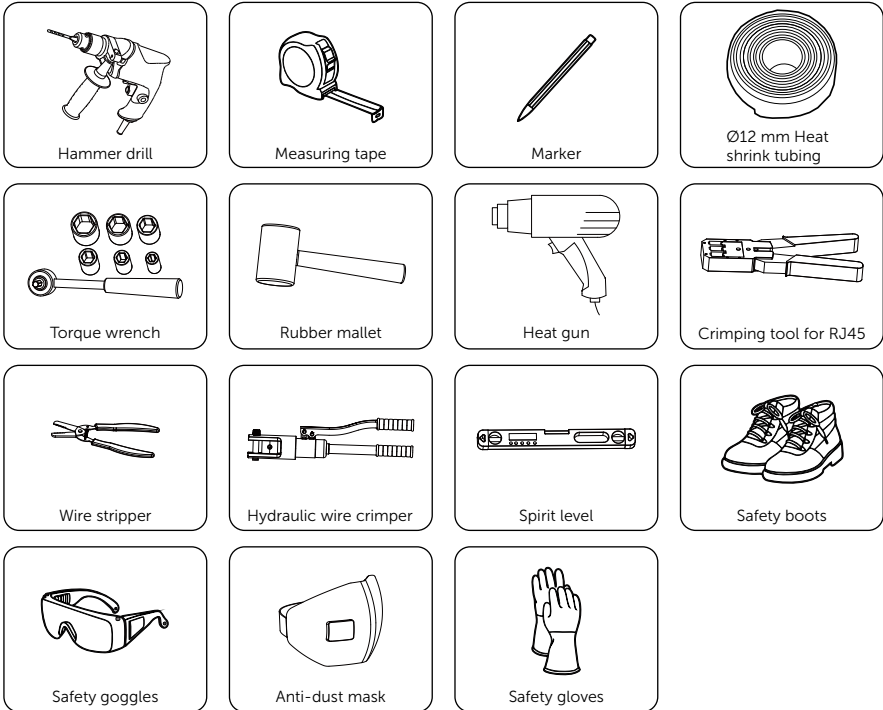

Figure 4-3 Clearance requirement about wall mounting

4.2 Tools Requirement

Installation tools include but are not limited to the following recommended ones. If necessary, use other auxiliary tools on site.



4.3 Additionally Required Materials

The following is a recommended list of equipment required for installation of the battery system.

Table 4-1 Additionally required wires

No.	Required Material	Type	Diameter/ Conductor Cross-section
1	Protective pipe	Corrugated pipe	External diameter: over 60 mm
2	Grounding cable	/	16 mm ²

5 Unpacking and Inspection

5.1 Unpacking

- The rechargeable battery undergoes 100% testing and inspection before shipping from the manufacturing facility. However, transport damage may still occur. Before unpacking the rechargeable battery, please verify that the model and outer packing materials for damage, such as holes and cracks.
- Unpacking the battery pack according to the following figures. If there are other cartons, such as the rack carton, cabinet carton, cables carton, or cartons about wall mounting, the unpacking procedure can also be referred to the following figures.

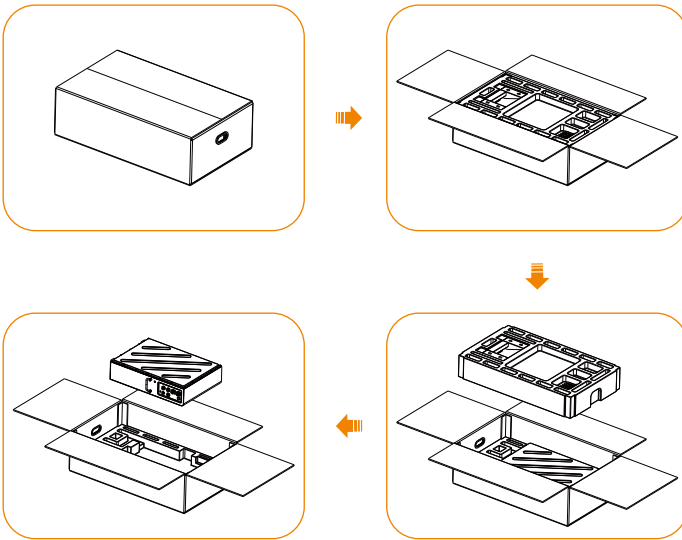

Figure 5-1 Unpacking the battery pack

- Be careful when dealing with all package materials which may be reused for storage and relocation of the rechargeable battery in the future.
- Upon opening the package, check whether the appearance of the rechargeable battery is damaged or lack of accessories. If any damage is found or any parts are missing, contact your dealer immediately.

5.2 Scope of Delivery

One Battery Pack (TP-LD53)

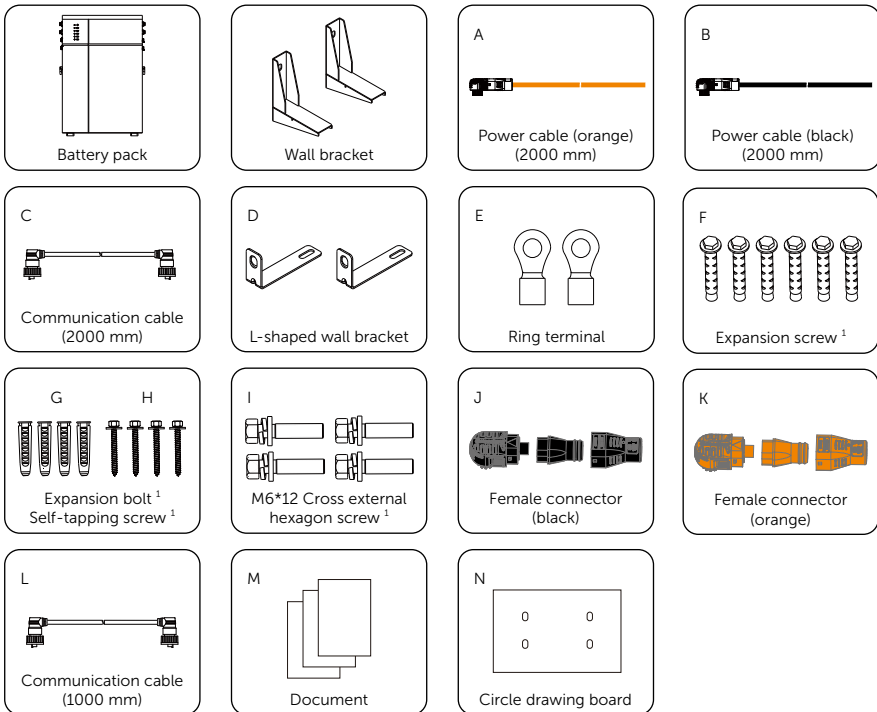

Table 5-1 Packing list of battery pack (TP-LD53)

Item No.	Description	Quantity (Unit: pc)
/	Battery pack	1
/	Wall bracket	2
A	Power cable (orange) (2000 mm)	1
B	Power cable (black) (2000 mm)	1
C	Communication cable (2000 mm)	1
D	L-shaped wall bracket	2
E	Ring terminal	2
F	Expansion screw ¹	6

Unpacking and Inspection

Item No.	Description	Quantity (Unit: pc)
G	Expansion bolt ¹	4
H	Self-tapping screw ¹	4
I	M6*12 cross external hexagon screw ¹	4
J	Female connector (black)	1
K	Female connector (orange)	1
L	Communication cable (1000 mm)	1
M	Document	/
N	Circle drawing board	1

NOTICE!

- The above accessories kit applies to the installation options of both floor mounting and wall mounting.
- The above items are only for one battery pack. Our company will provide corresponding components according to the battery packs.
- The accessory with the superscript "1" indicates that SolaX will give the user two extra free accessories away.

Accessories Kit for Cables (for two adjacent battery packs)

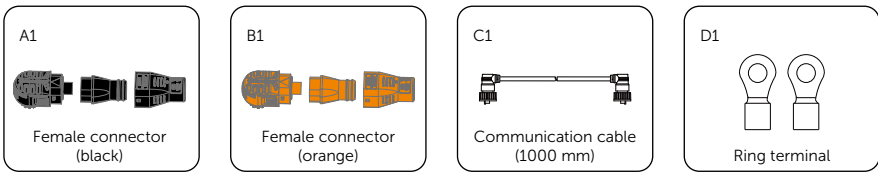

Table 5-2 Packing list of accessories kit for cables

Item No.	Description	Quantity (Unit: pc)
A1	Female connector (black)	1
B1	Female connector (orange)	1
C1	Communication cable (1000 mm)	1
D1	Ring terminal	2

NOTICE!

- The above accessories required for parallel operation are included in the battery accessories kit and do not need to be purchased. Only in the event of missing or damaged accessories on site is it necessary to purchase accessories kit.

6 Mechanical Installation

6.1 Installation Options

There are two installation options (floor mounting and wall mounting) are available, with details as follows:

Option A: Floor Mounting

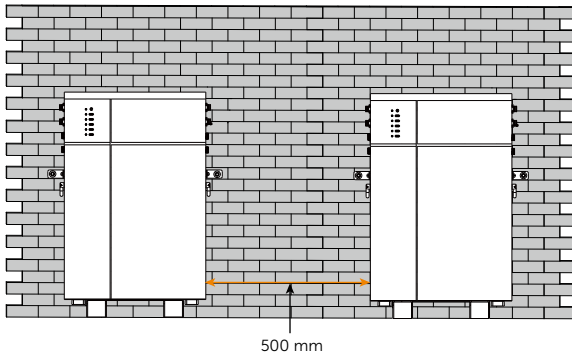

Option B: Wall Mounting

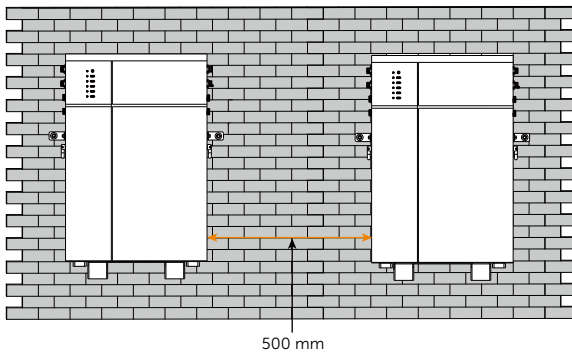

Figure 6-1 Installation options

NOTICE!

- The Figure 6-1 takes two battery packs as an example.
- Both the floor mounting and the wall mounting may withstand up to sixteen battery packs.

6.2 Installation Procedure

WARNING!

- Only the qualified personnel can perform the mechanical installation following the local standards and requirements.
- Check the existing power cables or other piping in the wall to prevent electric shock or other damage.
- The bi-directional energy storage inverter connected with the battery pack must be an isolated inverter.

CAUTION!

- Always be aware of the weight of the battery. Personal injuries may result if the battery is lifted improperly or dropped while being transported or mounted.
- Be sure you have all the proper protective clothing, safety tools, and equipment on hand before starting the installation.
- Keep the work area clean and well lit. Cluttered or dark areas invite accidents.

NOTICE!

- Both the floor and wall mounting may withstand up to sixteen battery packs.

Table 6-1 Number of battery pack

	Floor mounting	Wall mounting
Max. number of battery packs	16	16

- Either the floor or wall mounting, the bearing capacity of the grounding or the wall, which enables it to bear the loads from the whole battery system, must be over 200 kg.

Table 6-2 Bearing capacity

	Floor mounting	Wall mounting
Bearing capacity of the supporting surface of a battery pack	≥ 200 kg	≥ 200 kg

- Either the floor or wall mounting, the distance from the battery pack to the wall, the neighbouring battery pack, or the grounding shall be provided as below.

Table 6-3 Distance requirement

	Floor mounting	Wall mounting
Distance from the edge of the battery pack to the wall	200 mm ~ 300 mm	200 mm ~ 300 mm
Distance from the back of the battery pack to the wall	55 mm	55 mm
Distance from the edge of the battery pack to the edge of the neighbouring battery pack	400 mm ~ 600 mm	400 mm ~ 600 mm
Distance from the bottom of the battery pack to the ground	/	300 mm ~ 350 mm

6.2.1 Floor Mounting

WARNING!

- The site for installing the battery pack must be level (no slope, no pothole).

NOTICE!

- Allow sufficient clearance between adjacent walls or equipment for proper installation of the battery pack.
- The following steps take one (1) battery pack as an example.

Step 1: Fix the L-shaped wall bracket (Part D) to the battery pack with M6*12 cross external hexagon screw (Part I) (× 2 pcs), but do not tighten them fully.

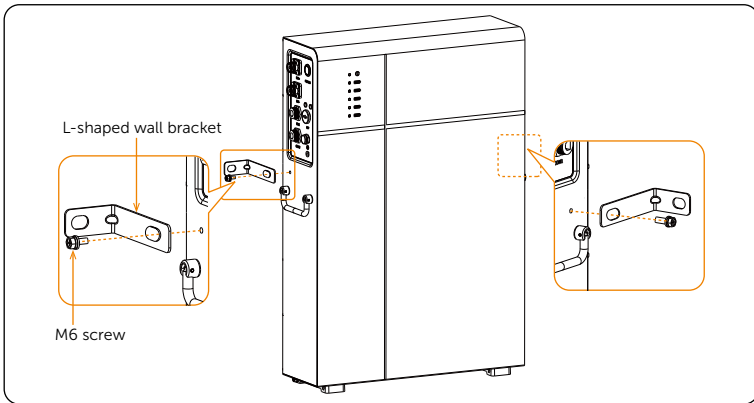

Figure 6-2 Fixing L-shaped wall bracket to the battery pack

NOTICE!

- Do not tighten the screws fully.

Step 2: Locate the L-shaped wall bracket against the wall.

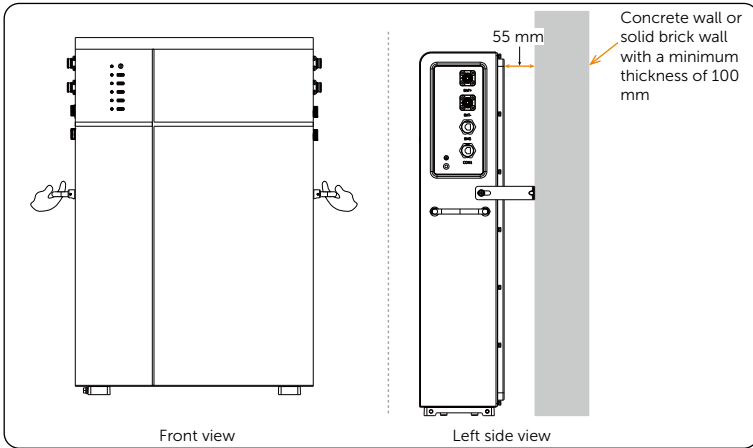

Figure 6-3 Locating the battery pack against the wall

NOTICE!

- At least two persons are required to lift the battery pack.

Step 3: Draw a circle along the inner ring, with one on each side. Then gently move the battery pack aside.

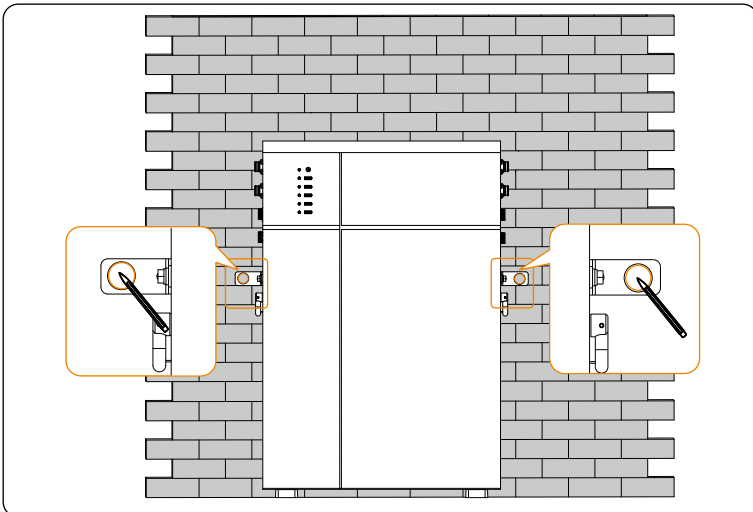

Figure 6-4 Drawing circles

Step 4: Drill two holes at a depth of more than 60 mm in the concrete wall (or solid brick wall) by using a Drill ($\varnothing 8$ mm).

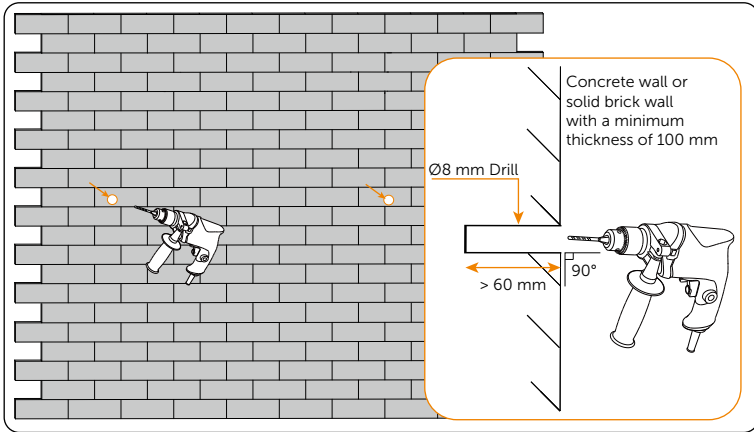

Figure 6-5 Drilling holes

NOTICE!

- The battery pack can only be installed on the concrete wall or the solid brick wall.
- To prevent angled holes from being drilled, it is suggested to use a $\varnothing 8$ mm Drill to drill holes first, and then change to a $\varnothing 10$ mm Drill.
- An electric drill dust collector is recommended.

Step 5: Insert the expansion bolt (Part G) (× 2 pcs) into the two holes.

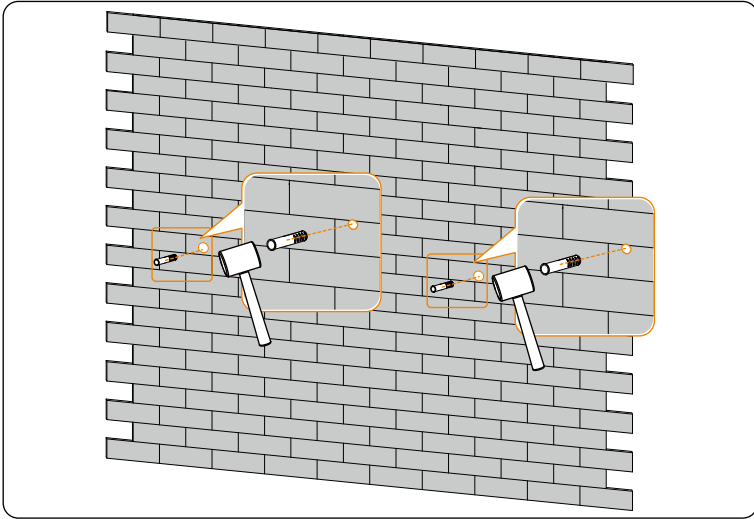

Figure 6-6 Inserting expansion bolts

Step 6: Gently move the battery pack against the wall, and align the holes drilled previously.

Correctly insert and tighten self-tapping screw (Part H) (× 2 pcs) to secure the L-shaped wall bracket on both sides to the wall (Tightening torque: 6-8 N·m).

Fully tighten the M6*12 cross external hexagon screw (× 2 pcs) on both sides (Tightening torque: 4-5 N·m).

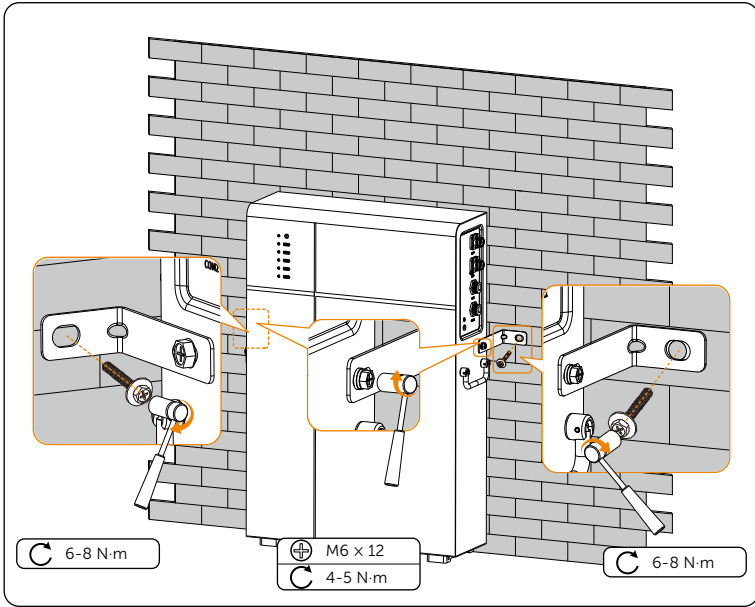

Figure 6-7 Tightening tapping screws and M6 screws

NOTICE!

- At least two persons are required to lift the battery pack.

Step 7: Repeat steps 1 to 6 to install the second battery pack, as well as the remaining battery packs (if any).

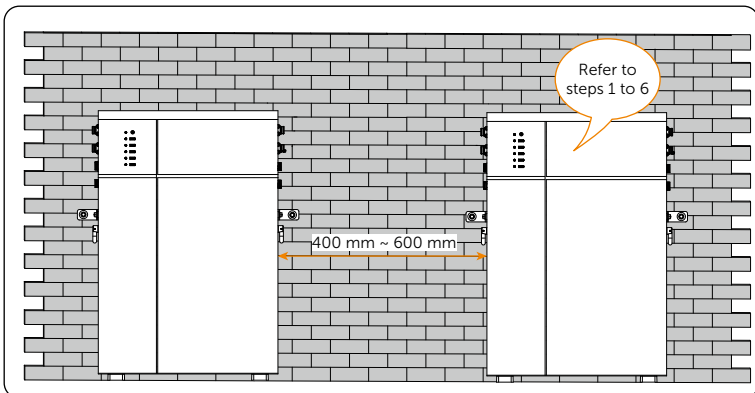

Figure 6-8 Installing the remaining battery pack

NOTICE!

- The distance between 400 and 600 mm wide shall be provided from the left side edge of a battery pack to the right side edge of the neighbouring battery pack.
- Up to sixteen (16) battery packs can be installed in a straight line.

6.2.2 Wall Mounting

Step 1: Attach the circle drawing board to the wall, and make sure that it is level via the cylindrical plastic bubble spirit level on the board.

Draw a circle along the inner ring on the board, with a total of 4 circles.

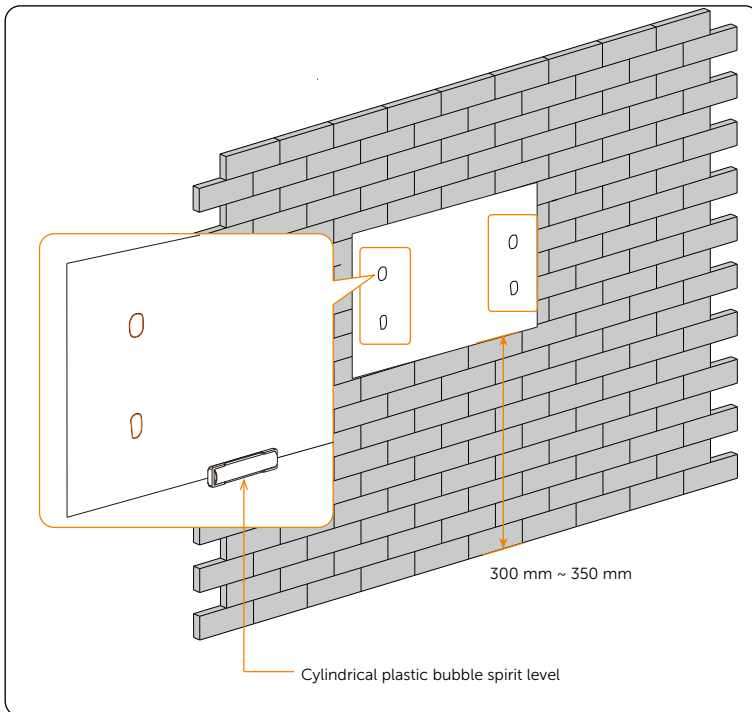

Figure 6-9 Drawing circles

NOTICE!

- A distance between 300 and 350 mm from the bottom of the circle drawing board to the ground must be reserved.

Step 2: Remove the circle drawing board, and then drill four holes at a depth of more than 90 mm in the concrete wall (or solid brick wall) by using a Drill ($\text{\O}12$ mm).

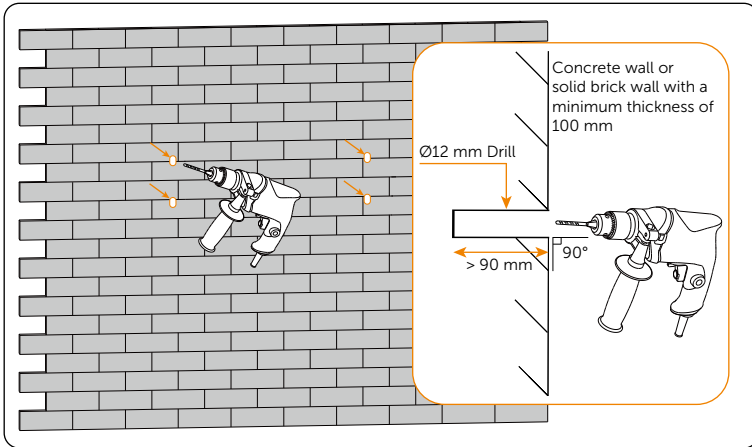

Figure 6-10 Drawing holes

NOTICE!

- To prevent angled holes from being drilled, it is suggested to use a $\text{\O}10$ mm Drill to drill holes first, and then change to a $\text{\O}12$ mm Drill.
- Currently, the battery pack can only be installed on the concrete wall or the solid brick wall.
- An electric drill dust collector is recommended.

Step 3: Attach the wall bracket to the wall, and correctly insert and tighten expansion screw (Part F) (x 4 pcs) to secure the wall bracket (Tightening torque: 14-16 N·m).

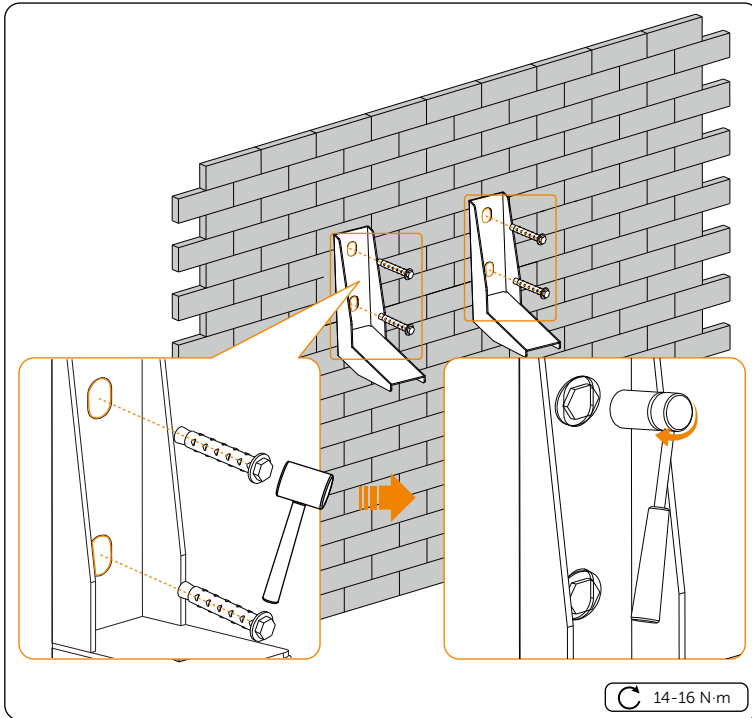

Figure 6-11 Tightening expansion screw

NOTICE!

- Please make sure that it is level via the cylindrical plastic bubble spirit level on the wall bracket.

Step 4: Fix the L-shaped wall bracket (Part D) to the battery pack with M6*12 cross external hexagon screw (Part I) (× 2 pcs), but do not tighten them fully.

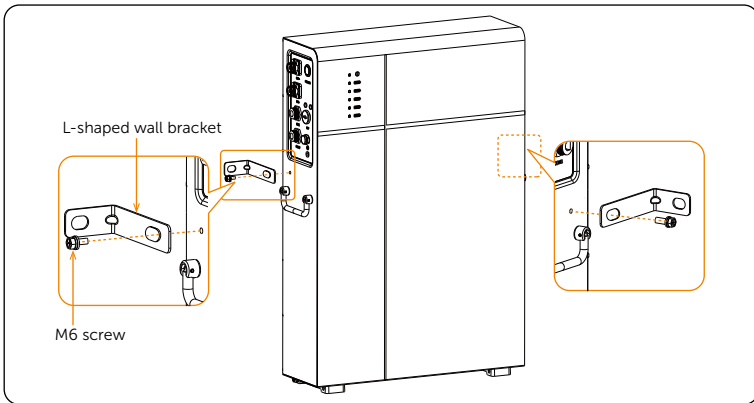

Figure 6-12 Fixing L-shaped wall bracket to the battery pack

NOTICE!

- Do not tighten the screws fully.

Step 5: Gently lift the battery pack onto the wall bracket, and locate it against the wall bracket.

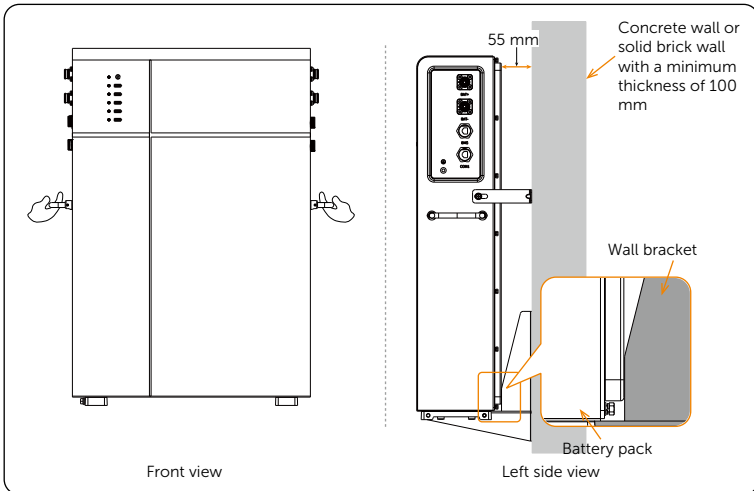

Figure 6-13 Lifting the battery pack

NOTICE!

- At least two persons are required to lift the battery pack.
- The battery pack shall be located against the wall bracket.

Step 6: Draw a circle along the inner ring, with one on each side.
Then gently carry the battery pack down to the ground.

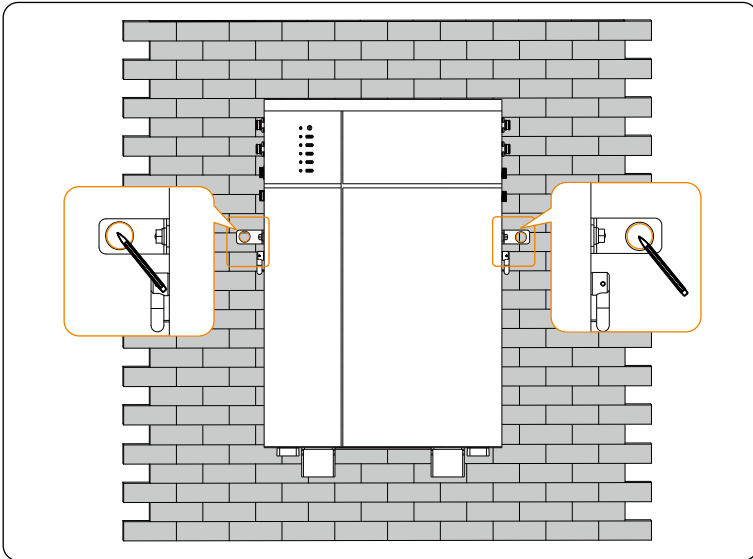

Figure 6-14 Drawing circles

NOTICE!

- It needs a second person to hold the battery pack to prevent it from falling from the wall bracket when installation.

Step 7: Drill two holes at a depth of more than 60 mm in the concrete wall (or solid brick wall) by using a Drill ($\varnothing 8$ mm).

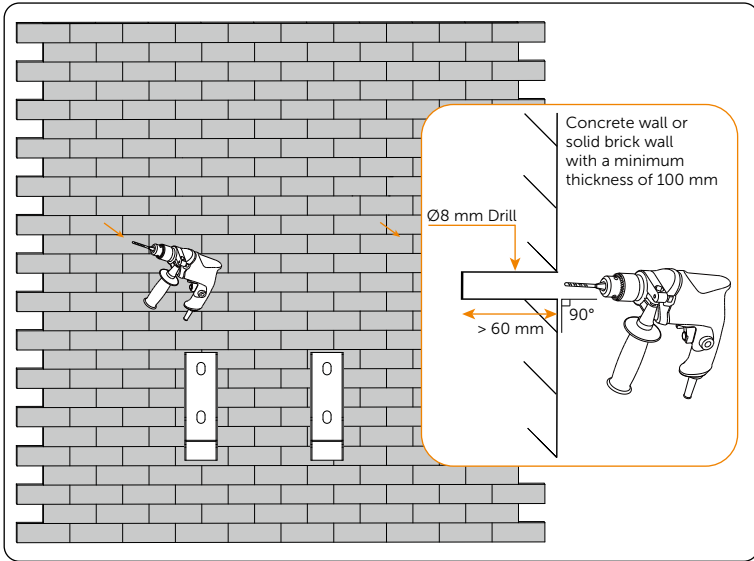

Figure 6-15 Drilling holes

NOTICE!

- Currently, the battery pack can only be installed on the concrete wall or the solid brick wall.
- To prevent angled holes from being drilled, it is suggested to use a $\varnothing 8$ mm Drill to drill holes first, and then change to a $\varnothing 10$ mm Drill.
- An electric drill dust collector is recommended.

Step 8: Insert the expansion bolt (Part G) (x 2 pcs) into the two holes.

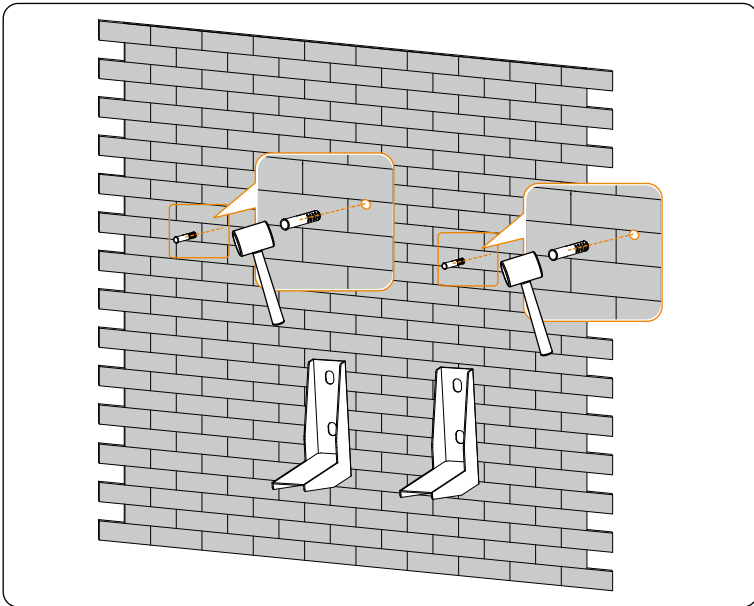

Figure 6-16 Insert expansion bolts

Step 9: Gently lift the battery pack onto the wall bracket, and locate it against the wall bracket.

Correctly insert and tighten self-tapping screw (Part H) (x 2 pcs) to secure the L-shaped wall bracket on both sides to the wall (Tightening torque: 6-8 N·m).

Fully tighten the M6*12 cross external hexagon screw (x 2) on both sides (Tightening torque: 4-5 N·m).

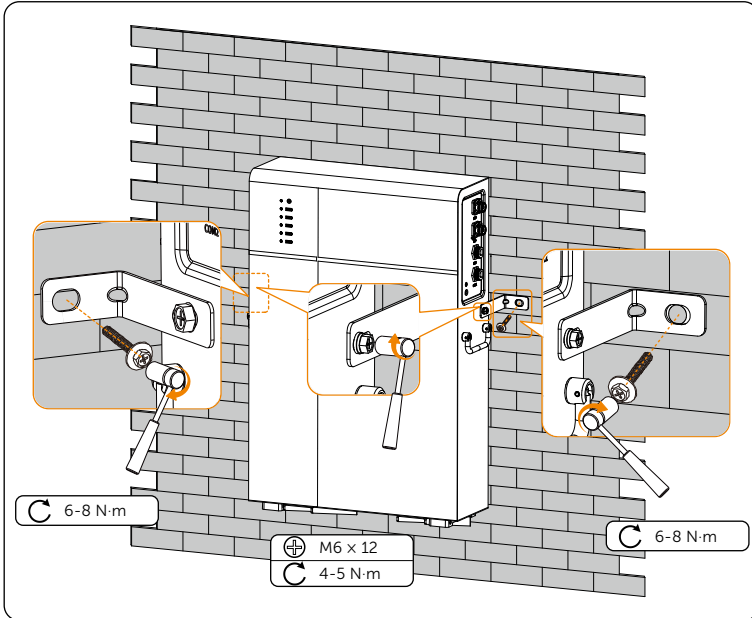

Figure 6-17 Tightening tapping screws and M6 screws

NOTICE!

- At least two persons are required to lift the battery pack.

Step 10: Repeat steps 1 to 9 to install the second battery pack, as well as the remaining battery packs (if any).

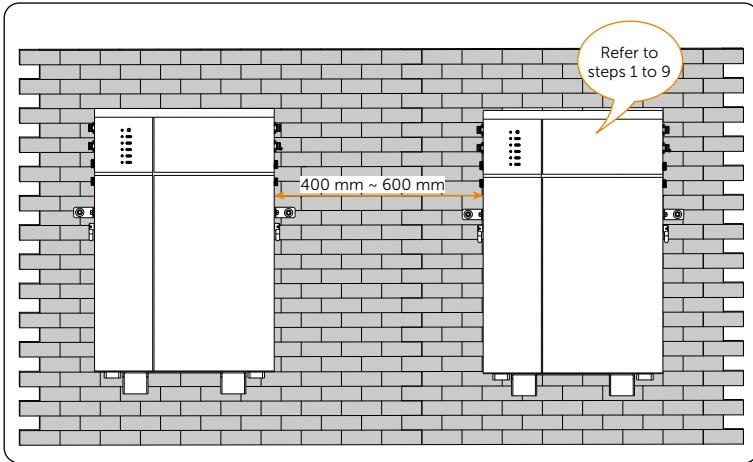

Figure 6-18 Installing the remaining battery pack

NOTICE!

- The distance between 400 and 600 mm wide shall be provided from the left side edge of a battery pack to the right side edge of the neighbouring battery packs.
- Up to sixteen (16) battery packs can be installed in a straight line.

7 Wiring





NOTICE!

- Regarding the PE and communication cable, of which one end connects to the inverter, it shall be made before conducting wiring.
- Regarding the power cable connecting two adjacent battery packs, the female connector onto the power cable must be made before conducting wiring.

7.1 Details of Cables

Cables in the Accessories Kit for Battery pack

Table 7-4 Details of cables

Cable	Length	Purpose	Qty
 Power cable (black)	2000 mm	There are two terminals at both ends: one connects to the "BAT-" port of a battery pack, and the other connects to the "BAT-" port of the inverter.	1 pc
 Power cable (orange)	2000 mm	There are two terminals at both ends: one connects to the "BAT+" port of a battery pack, and the other connects to the "BAT+" port of the inverter.	1 pc
 Communication cable	2000 mm	There are two terminals at both ends: one connects to the "BMS" port of a battery pack, and the other connects to the "BMS" port of the inverter.	1 pc
 Communication cable	1000 mm	There are two terminals at both ends: one connects to the "COM1" port of the battery pack, and the other connects to the "COM2" port of the adjacent battery packs.	1 pc

Cables in the Accessories Kit for Cables (for two adjacent battery packs)

NOTICE!

- The cables in the following table are delivered with the Accessories Kit for Cables, which needs to be purchased separately.

Table 7-5 Details of cables

	There are two terminals at both ends: one connects to the "COM1" port of the battery pack, and the other connects to the "COM2" port of the adjacent battery packs.	1 pc
Communication cable 1000 mm		

7.2 PE Connection

The steps for making PE connection are shown as follows:

Step 1: Strip the cable jacket about 12 to 15 mm from the end.

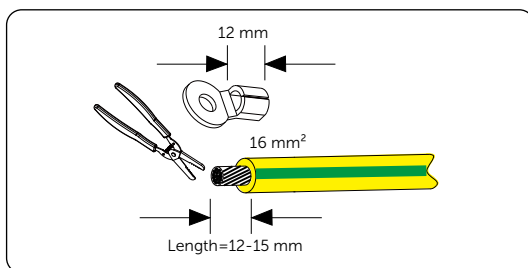

Figure 7-1 Stripping cable jacket

Step 2: Cut the heat-shrink tubing to about 28 to 30 mm long, carefully slide it onto the end of the cable, and then carefully slip the wires all the way into the ring terminal (Part E).

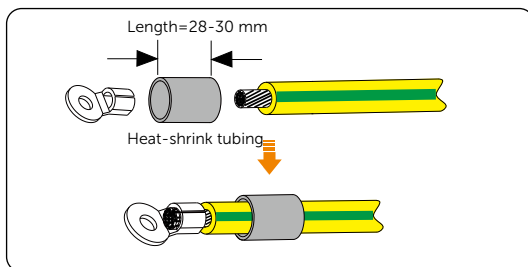

Figure 7-2 Cutting heat-shrink tubing

Step 3: Crimp the terminal, and heat the heat-shrink tubing after it wraps the end of terminal.

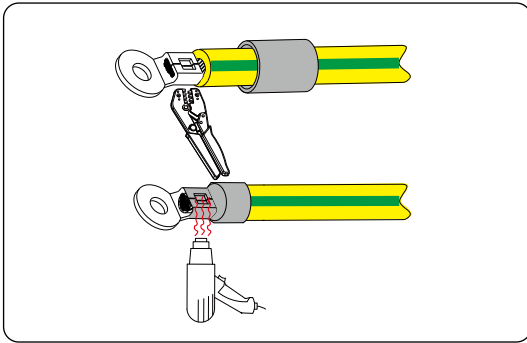

Figure 7-3 Crimping and heating

Step 4: Unscrew the M5 screw, and then connect the assembled grounding cable to the grounding port of the battery pack, and then tighten M5 screw (Tightening torque: 2.5-3 N·m).

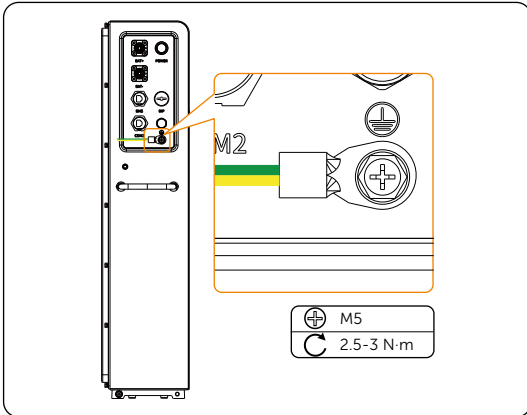

Figure 7-4 Tightening M5 screws

NOTICE!

- Regarding the grounding cable that is prepared by the user, a wire size of 16 mm² for the cable is recommended.

7.3 Communication Connection

To ensure normal operation between the battery pack and inverter, the communication cable connecting from the battery pack to the inverter is required to connect RJ45 connector.

Make sure that the "BMS" port on the battery pack connects to the inverter is Pin to Pin. The "BMS" port pin assignment is shown as follows:

Table 7-1 "BMS" port pin assignment

PIN	1	2	3	4	5	6	7	8
BMS	RS485B	RS485A	GND	CAN-H	CAN-L	12V-OUT	MASTER-IN	/

The wire sequence of one terminal connecting to the inverter is the same as the wire sequence of the other terminal, connecting to the battery pack.

The wire sequence is shown as follows:

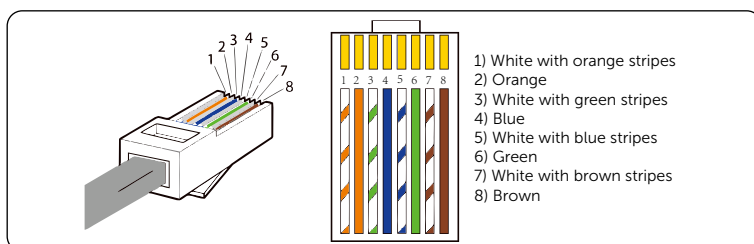

Figure 7-5 Wire sequence

The steps for making RJ45 connector to communication cable (Part C) are shown as follows:

- Step 1:** Strip the cable jacket about 15 mm down from the end.
- Step 2:** Carefully insert the wires all the way into the RJ45 connector, making sure that each wire passes through the appropriate guides inside the connector.
- Step 3:** Push the RJ45 inside the crimping tool and squeeze the crimper all the way down.

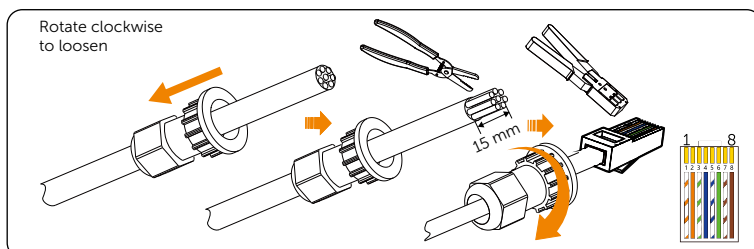

Figure 7-6 Making RJ45 connector to communication cable

NOTICE!

- The communication cable shall have a shield layer.
- The communication cable is delivered with the Accessories Kit for Cables.

7.4 Ring Terminal Installation

Ring terminals are connectors for power cables. They are designed to connect the end of a power cable to a circuit point.

To connect the power cable to the circuit point on the **inverter**, a ring terminal is required to be fit over the power cable. The installation procedure of ring terminal onto the power cable is shown as follows:

Step 1: Take out the power cables (Parts A and B), and with care, strip the cable jacket about 10 mm from the end.

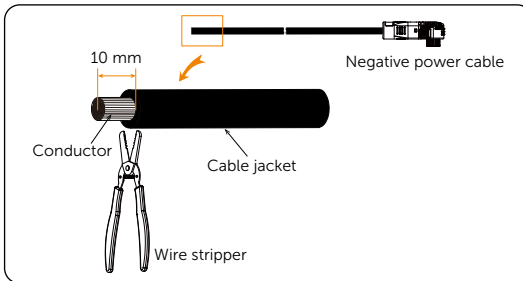

Figure 7-7 Stripping power cable

NOTICE!

- DO NOT damage the conductor while sliding the jacket off the power cable end.

Step 2: Fit the ring terminal over the conductor strands, and squeeze the crimping tool to crimp the terminal.

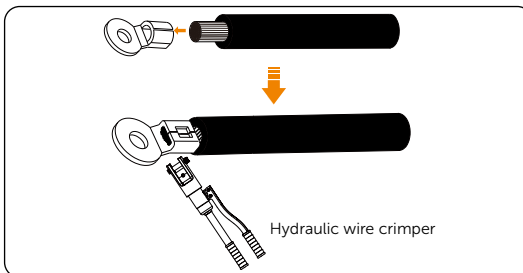

Figure 7-8 Crimping terminal

NOTICE!
<ul style="list-style-type: none"> • Properly place the ring terminal into the MC4 crimping tool.

Step 3: Make the positive power cable according to the above two steps.

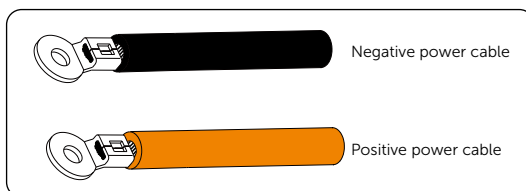

Figure 7-9 Making power cables

NOTICE!
<ul style="list-style-type: none"> • The ring terminals are delivered with the inverter's accessories kit. • Please refer to the inverter's User Manual for further installation steps.

7.5 Female Connector Installation

A power cable consists of a flexible cord with connectors, male and female. Since the power cables provided are only attached to the male connector, the female connector must be installed onto the power cable by the user himself/herself before conducting wiring between **battery packs**. The installation procedure of female connector onto the power cable is shown as follows:

Step 1: Take out the power cables (Parts A and B), and connectors (Parts J and K) (including connector body, cable seal ring, and tail cover).

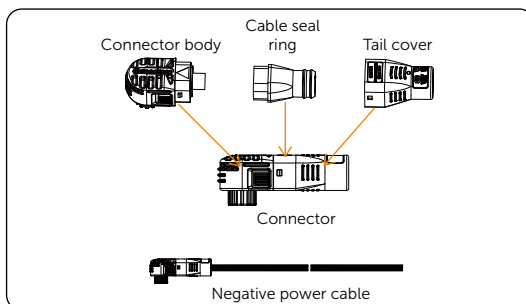

Figure 7-10 Taking out accessories

NOTICE!

- To ensure that both connectors and power cables are connected correctly, an orange female connector shall be connected to the orange power cable, as well as a black female connector to the black power cable.

Step 2: Orderly insert the stripped wire into the tail cover and cable seal ring.

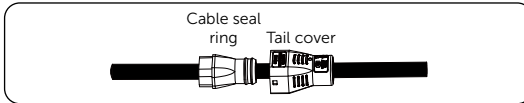

Figure 7-11 Inserting the stripped wire

Step 3: With care, strip the cable jacket about 15 ± 1 mm from the end.

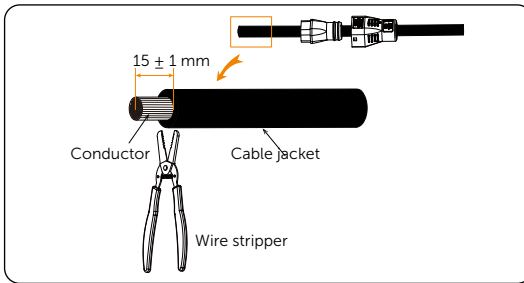

Figure 7-12 Striping cable jacket

NOTICE!

- DO NOT damage the conductor while sliding the jacket off the power cable end.
- The wire size of the power cable delivered with the accessories kit is 25 mm^2 (3 AWG).

Step 4: Fit the connector body over the conductor strands, and squeeze the crimper to crimp the terminal. The conductor strands exposed shall not be over 1 mm.

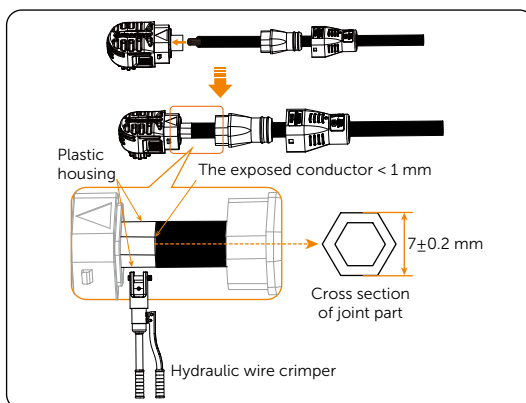

Figure 7-13 Fitting connector body and crimping terminal

NOTICE!

- Properly place the plastic housing into a hydraulic wire crimper.
- DO NOT place the conductor insulation into the connector body.
- DO NOT crush the plastic housing while crimping.
- DO NOT crush or damage the conductor insulation while crimping.

Step 5: Orderly push the cable seal ring and tail cover into the body. The sound of "Click" will be heard when the tail cover is properly plugged into the body.

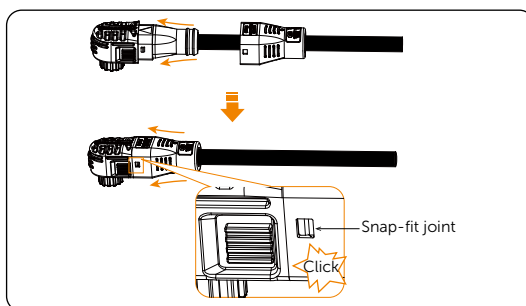

Figure 7-14 Assembling connector

NOTICE!

- User should hear the sound of "Click" while pressing the tail cover into the location position.

Step 6: Make the positive power cable according to the above steps.

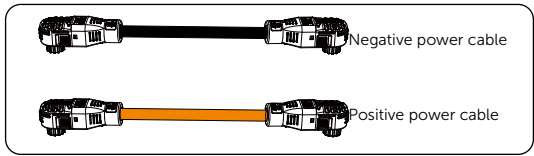

Figure 7-15 Making positive power cable

After finishing the installation of the female connector onto the power cable, and due to the special terminal connector on the power cable, please note the following details.

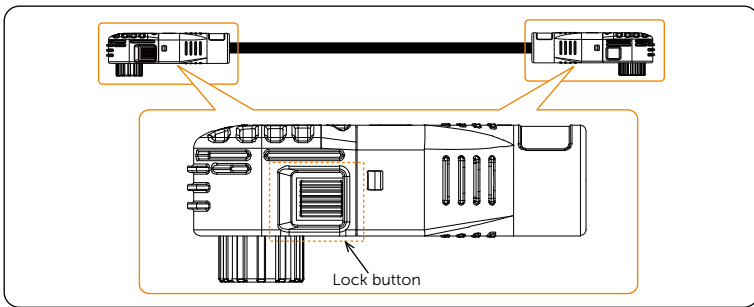

Figure 7-16 Lock button

NOTICE!

- The Figure 7-16 is the power cable that finishes the installation of the female connector.
- Press and hold the "Lock button" while unplugging the power cable. Otherwise, it cannot be pulled out.
- Don't violently remove the power cables when they are locked.

7.6 Wiring Procedure

WARNING!

- Only the qualified personnel can perform the wiring.
- Follow this manual to wire connection. The device damage caused by incorrect cabling is not in the scope of warranty.
- Inspect each terminal for visual signs of mechanical defects.

CAUTION!

- Use insulated tools and wear individual protective tools when connecting cables.
- Do not bend the power cable, particularly at the point where the cable joins the connector, at 90° while conducting wiring.
- When the cable insulation layer is chewed through, this can cause short circuits and potentially start an electrical fire. Therefore, where there is a risk of pests, rodents, or termites, protective barriers or additives are suggested to be added to the cables to prevent damage.

NOTICE!

- The electrical connection areas on both sides of the battery pack are allowed to conduct wiring with the inverter.
- The wiring procedure applies to both floor mounting and wall mounting.

7.6.1 The Right Electrical Connection Area of the Battery pack Selected to Be Connected to the Inverter

Cable connection for only one battery pack

Step 1: Connect the negative power cable to the "BAT-" ports of the battery pack and inverter.

Connect the positive power cable to the "BAT+" ports of the battery pack and inverter.

Connect the communication cable (Part C) to the "BMS" ports of the battery pack and inverter.

Make sure that power cables and communication cable are wired correctly, as shown in Figure 7-17. Failing to do so may cause severe damage to your battery pack.

Table 7-2 Cable information

Cable	Length	Purpose (from battery pack to inverter)	Qty
Communication cable	2000 mm	"BMS" port to "BMS" port	1 pc
Power cable (black)	2000 mm	"BAT-" port to "BAT-" port	1 pc
Power cable (orange)	2000 mm	"BAT+" port to "BAT+" port	1 pc

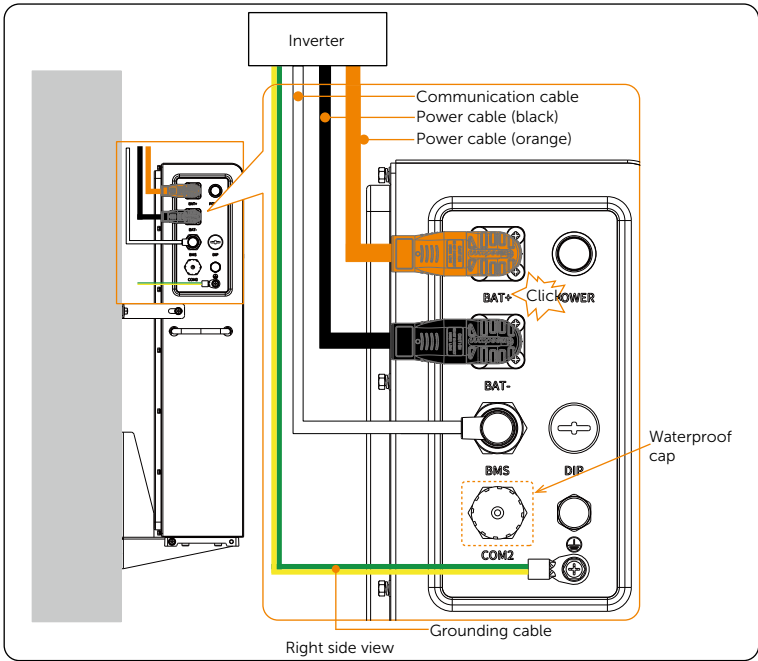

Figure 7-17 Cable connection of the right electrical connection area

NOTICE!

- Regarding the making process of grounding cable, please refer to "[PE Connection](#)".
- Regarding the making process of communication cable, please refer to "[Communication Connection](#)".
- A sound of "Click" should be heard while plugging in the power cables. It indicates that the cable connectors are properly plugged into the ports.
- The waterproof cap has been covered before delivery.
- Don't violently remove the power cables when they are locked.

Tip: Use safety gloves when connecting battery packs.

Cable connection for two or more battery packs

Since the wiring procedure of two battery packs is the same as that of more than two battery packs, the wiring procedure of two battery packs is taken as an example.

The general wiring diagram of two battery packs is shown below:

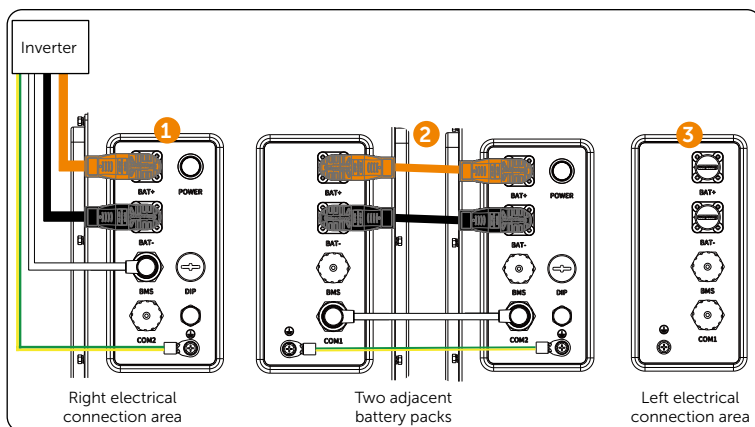

Figure 7-18 Wiring diagram of two battery packs

The detailed connection procedure is shown as follows:

Step 1: Connect the negative power cable to the "BAT-" ports of the battery pack and inverter.

Connect the positive power cable to the "BAT+" port of the battery pack and inverter.

Connect the communication cable (Part C) to the "BMS" port of the battery pack and inverter.

Make sure that power cables and communication cable are wired correctly, as shown in Figure 7-20. Failing to do so may cause severe damage to your battery pack.

Table 7-3 Cable information

Cable	Length	Purpose (incl. from battery pack to inverter, battery pack to battery pack)	Qty
-------	--------	--	-----

Communication cable	2000 mm	"BMS" port to "BMS" port	According to the actual number of the battery packs
Power cable (black)	2000 mm	"BAT-" port to "BAT-" port	
Power cable (orange)	2000 mm	"BAT+" port to "BAT+" port	

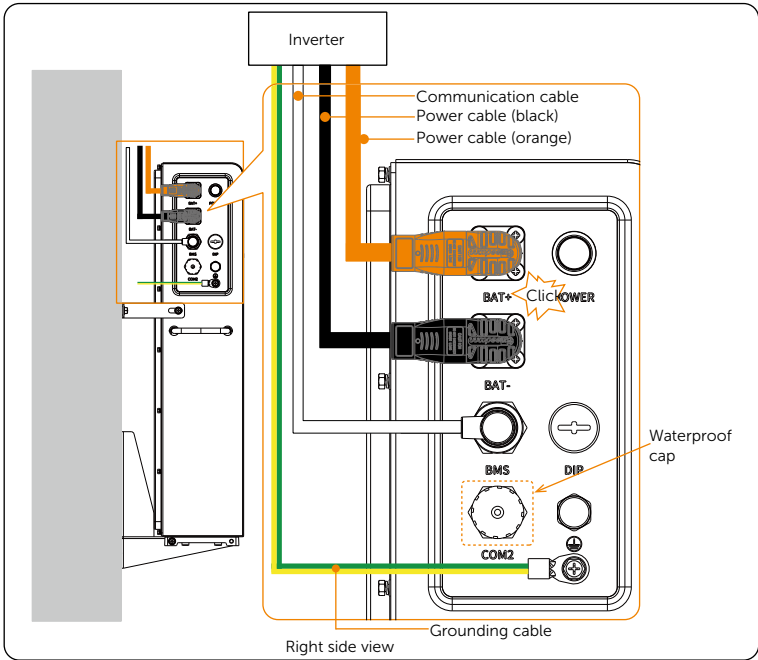

Figure 7-19 Cable connection of the right electrical connection area

NOTICE!

- Regarding the making process of grounding cable, please refer to "[PE Connection](#)".
- Regarding the making process of communication cable, please refer to "[Communication Connection](#)".
- A sound of "Click" should be heard while plugging in the power cables. It indicates that the cable connectors are properly plugged into the ports.
- The waterproof cap has been covered before delivery.
- Don't violently remove the power cables when they are locked.

- Step 2:** Connect the negative power cable to the "BAT-" ports of adjacent battery packs. Connect the positive power cable to the "BAT+" ports of adjacent battery packs. Connect the communication cable (Part L) to the "BMS" ports of adjacent battery packs.
- Make sure that power cables and communication cable are wired correctly, as shown in Figure 7-21. Failing to do so may cause severe damage to your battery pack.

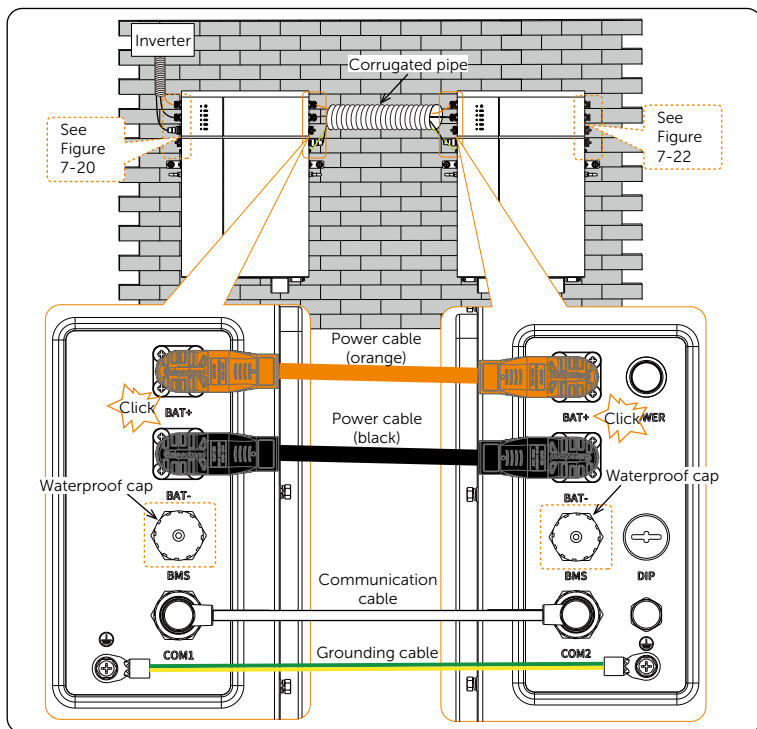

Figure 7-20 Cable connection between adjacent battery pack

NOTICE!

- Regarding the making process of power cable, please refer to ["Installation of Female Connector onto Power Cable"](#).
- A corrugated pipe with an external diameter of 60 mm is recommended for use to keep cable insulation in place and avoid potential damages, when conducting wiring between two adjacent battery packs.
- A sound of "Click" should be heard while plugging in the power cables. It indicates that the cable connectors are properly plugged into the ports.
- Don't violently remove the power cables when they are locked.

Tip: Use safety gloves when connecting battery packs.

7.6.2 The Left Electrical Connection Area of the Battery pack Selected to Be Connected to the Inverter

Cable connection for only one battery pack

Step 1: Connect the negative power cable to the "BAT-" ports of the battery pack and inverter.

Connect the positive power cable to the "BAT+" ports of the battery pack and inverter.

Connect the communication cable (Part C) to the "BMS" ports of the battery pack and inverter.

Ensure that power cables and communication cable are wired correctly, as shown in Figure 7-23. Failing to do so may cause severe damage to the battery pack.

Table 7-4 Cable information

Cable	Length	Purpose (from battery pack to inverter)	Qty
Communication cable	2000 mm	"BMS" port to "BMS" port	1 pc
Power cable (black)	2000 mm	"BAT-" port to "BAT-" port	1 pc
Power cable (orange)	2000 mm	"BAT+" port to "BAT+" port	1 pc

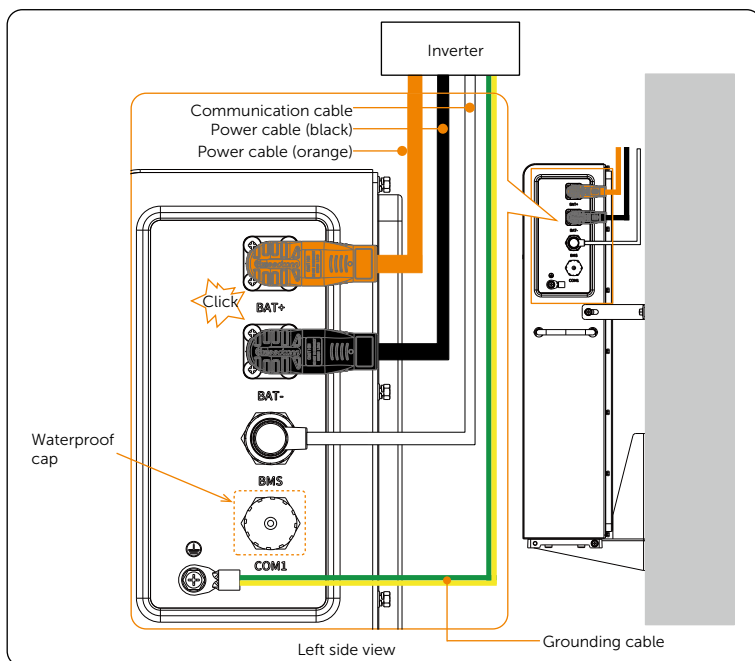

Figure 7-21 Cable connection of the left electrical connection area

NOTICE!

- Regarding the making process of grounding cable, please refer to "[PE Connection](#)".
- Regarding the making process of communication cable, please refer to "[Communication Connection](#)".
- A sound of "Click" should be heard while plugging in the power cables. It indicates that the cable connectors are properly plugged into the ports.
- The waterproof cap has been covered before delivery.
- Don't violently remove the power cables when they are locked.

Tip: Use safety gloves when connecting battery packs.

Cable connection for two or more battery packs

Since the wiring procedure of two battery packs is the same as that of more than two battery packs, the wiring procedure of two battery packs is taken as an example.

The general wiring diagram of two battery packs is shown below:

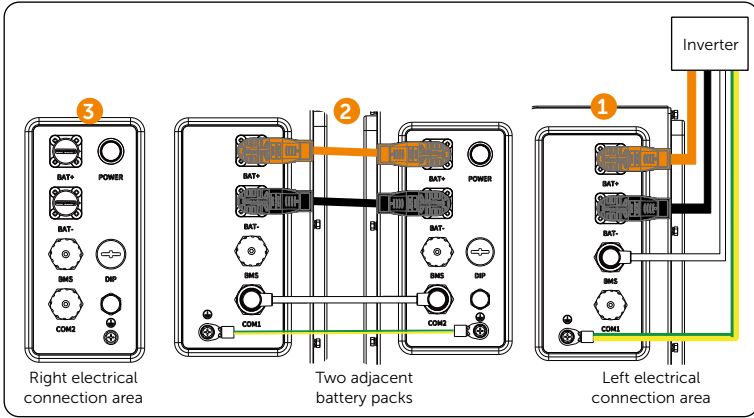

Figure 7-22 Wiring diagram of two battery pack

The detailed connection procedure is shown as follows:

Step 1: Connect the negative power cable to the "BAT-" ports of the battery pack and inverter.

Connect the positive power cable to the "BAT+" ports of the battery pack and inverter.

Connect the communication cable (Part C) to the "BMS" ports of the battery pack and inverter.

Make sure that power cables and communication cable are wired correctly, as shown in Figure 7-26. Failing to do so may cause severe damage to your battery pack.

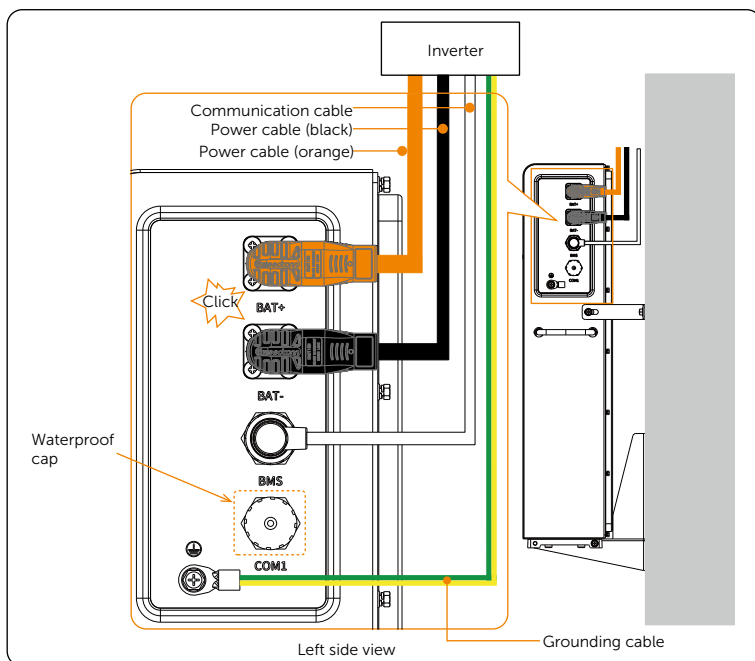

Figure 7-23 Cable connection of the left electrical connection area

NOTICE!

- Regarding the making process of grounding cable, please refer to "[PE Connection](#)".
- Regarding the making process of communication cable, please refer to "[Communication Connection](#)".
- A sound of "Click" should be heard while plugging in the power cables. It indicates that the cable connectors are properly plugged into the ports.
- Don't violently remove the power cables when they are locked.

- Step 2:** Connect the negative power cable to the "BAT-" ports of adjacent battery packs. Connect the positive power cable to the "BAT+" ports of adjacent battery packs. Connect the communication cable (Part L) to the "BMS" ports of adjacent battery packs.

Make sure that power cables and communication cable are wired correctly, as shown in Figure 7-27. Failing to do so may cause severe damage to your battery pack.

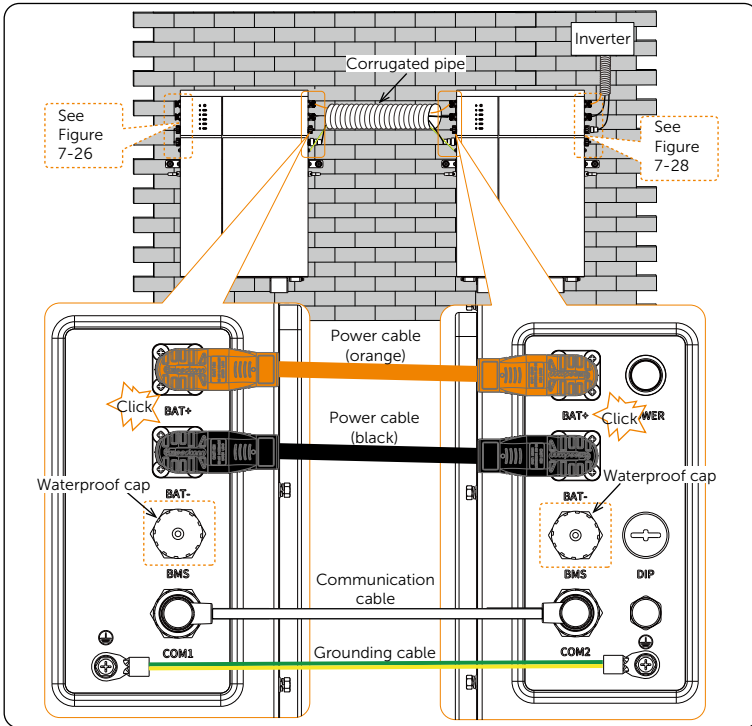

Figure 7-24 Cable connection of two adjacent battery pack

NOTICE!

- Regarding the making process of power cable, please refer to "[Installation of Female Connector onto Power Cable](#)".
- A corrugated pipe with an external diameter of 60 mm is recommended for use to keep cable insulation in place and avoid potential damages, when conducting wiring between two adjacent battery packs.
- A sound of "Click" should be heard while plugging in the power cables. It indicates that the cable connectors are properly plugged into the ports.
- Don't violently remove the power cables when they are locked.

Tip: Use safety gloves when connecting battery packs.

8 Parallel Connection

8.1 Wiring of Parallel Connection

The wiring diagram among inverter, parallel box and battery cluster is shown as follows:

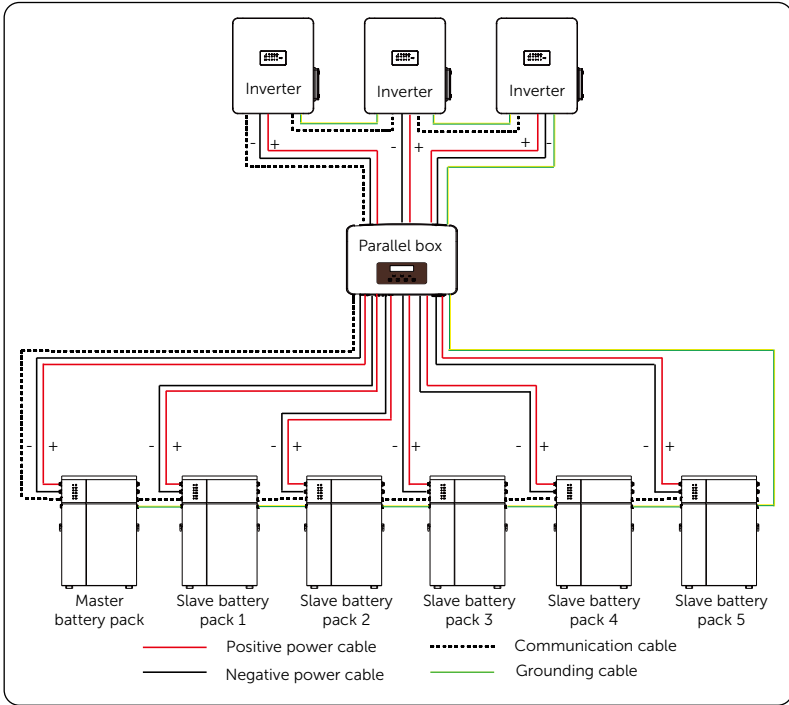

Figure 8-1 Wiring diagram of parallel connection

NOTICE!

As for parallel connection, it may have to dismantle the inverter or the battery. In that case, please strictly follow the *User Manual* to remove or install.

- Please confirm that there is enough space to increase the number of battery clusters.
- Please make sure that the ground and wall that are used to install the new battery clusters can handle the additional weight.

8.2 Materials Requirement

The battery is allowed to be connected in parallel by installing parallel box. As for the parallel box and related cables, users need to provide for themselves on their actual needs.

Power Cable Requirement

In addition to power cables included in accessories kit, users may need to provide power cables for themselves according to different currents. The suitable power cables are as follows:

Table 8-1 Power cables for parallel connection

No.	Current (A)	Cross-sectional Area (mm ²)
1	200	≥50
2	250	≥70
3	300	≥95
4	400	≥120

Wiring Requirement for Cooper Bar of Parallel Box

NOTICE!

Requirements for the positive and negative copper bars:

- The recommended distance between the positive and negative copper bars is greater than 20mm.
- The recommended distance between wiring holes on the copper bars is greater than 40mm.
- To the capacity expansion for 6 battery clusters, the recommended cross-sectional area for the copper bars is 250 (50*5) mm².

NOTICE!

Requirements for the positive and negative power cables of cooper bar wiring:

- The recommended length of the positive and negative power cables is less than 3m.
- The length of all power cables should be consistent.
- To the power cables connecting the battery, KST RNBL38-8 terminals are recommended for crimping.

9 Connection to the Third-party Inverter

9.1 Cable Connection

9.1.1 Connection of Capacity Expansion

Step 1: Connect the negative power cable to the "BAT-" ports of the master battery pack and inverter.

Connect the positive power cable to the "BAT+" ports of the master battery pack and inverter.

Connect the communication cable to the "BMS" ports of the master battery pack and inverter.

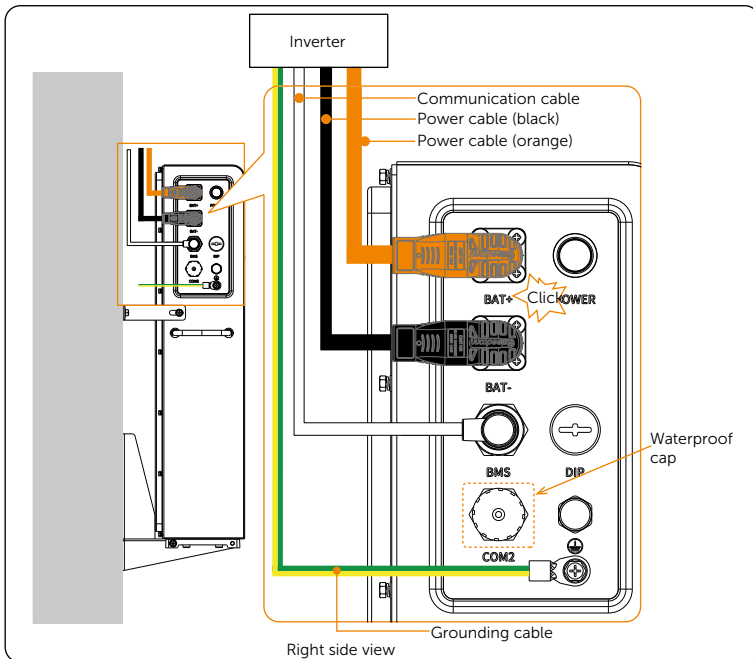

Figure 9-1 Cable connection between the master battery pack and inverter

- Step 2:** Connect the negative power cable to the "BAT-" ports of adjacent battery packs.
 Connect the positive power cable to the "BAT+" ports of adjacent battery packs.
 Connect the communication cable to the "BMS" ports of adjacent battery packs.

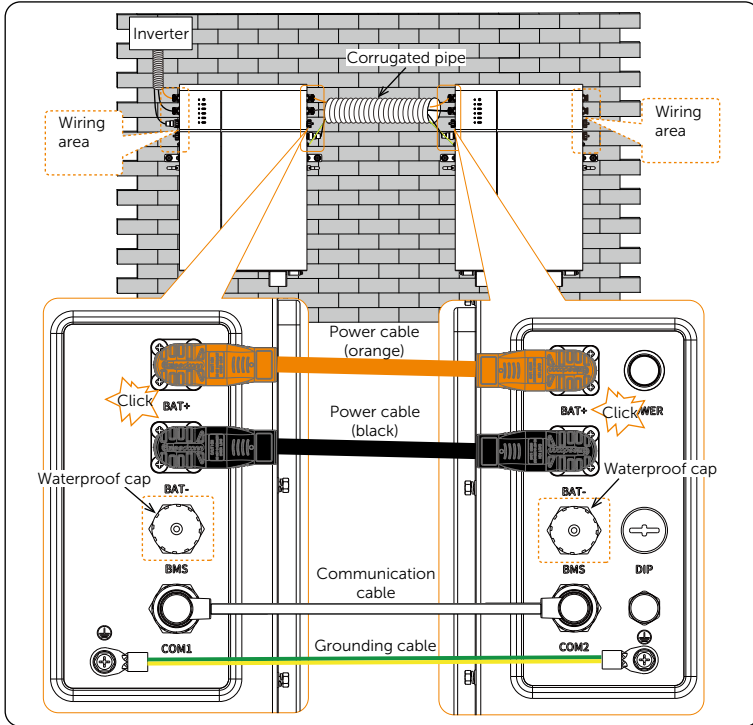

Figure 9-2 Cable connection between adjacent battery pack

9.1.2 Connection of Power Expansion

- Step 1:** Flip down the DIP switches 1~4 of the master battery pack to the "ON" position.
 Do not operate the DIP switches of slave battery packs.

NOTICE!

- When connecting the SolaX inverter, do not perform "Step 1".
- Usually, the DIP switch 5 will be slid to the "ON" position in the factory settings. Do not flip it up to the "OFF" position.

- Step 2:** Connect positive power cables to "B+" ports of all battery packs and inverter;
Connect negative power cables to "B-" ports of all battery packs and inverter.
Connect communication cables to the "BMS" ports of all battery packs and inverter.

NOTICE!

- For diagram after finishing wiring, please refer to "Figure 8-1 Wiring diagram of parallel connection"

9.2 Powering-on of the Third-party Inverter

First Commissioning

When first commissioning, users need to manually activate the black start before powering on to assign each battery module in a communication loop a unique address (battery number).

Please do as follows:

- Step 1:** Press and hold the "POWER" button on the master battery pack for 15 seconds. In the meantime, the status light will flash yellow, and the SOC power indicator will remain on solid green based on the battery module's actual battery capacity. At this point, release the button.
- Step 2:** The assignment will be completed when the status light flashes green every second. In the meantime, the battery will be automatically powered on.
- Step 3:** Press the "POWER" button three times within 10 seconds to ensure the battery remains powering on.
- Step 4:** All battery status lights will flash green every second after powering on.

After the First Commissioning

For powering-on steps after the first commissioning, please do as follows:

- Step 1:** Press the "POWER" button on the master battery pack for 2 seconds, and release it when the status light turns yellow.
- Step 2:** Wait for 15 seconds, and then the status light will be solid green.
- Step 3:** Within 10 seconds after turning solid green, press the "POWER" button three times to power on the battery.
- Step 4:** All battery status lights will flash green every second after powering on.

10 System Commissioning

10.1 Checking before Power-on

- a. Check the device installed correctly and securely;
- b. Make sure that Power button is OFF;
- c. All cables are connected correctly and securely;
- d. All unconnected port are covered;

10.2 Powering on/off the System

Power on: Press and hold the POWER button on the right electrical connection area of the battery pack that connects to the inverter until the LED lights appear.

Power off: Press and hold the POWER button on the right electrical connection area of the battery pack that connects to the inverter until the LED lights go out.

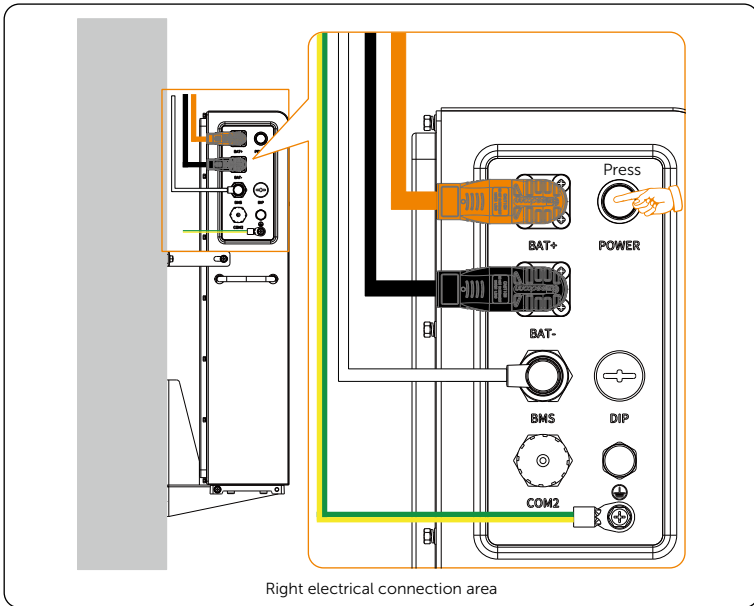

Figure 10-1 Power on/off the system

NOTICE!

- **Regarding the first start, after pressing and holding the POWER button on the battery pack that connects to the inverter for 15 seconds, the battery system will assign each battery pack in a communication loop a unique address (battery number).** In the meantime, the status light will remain on **solid yellow** for the first **11** seconds and then turn to **solid green**, and the SOC power indicators will remain on **solid blue** based on the battery packs' actual battery capacity. After 15 seconds, the status light will **flash yellow**, and at the same time, release the button. In the meantime, the unique address (battery number) will be assigned. The status light will turn to **flash green** or **solid green** after finishing the address assignment. Then the user can press the button to shut down the system.
- **Regarding the second start, after pressing the POWER button on the battery pack that connects to the inverter for less than 3 seconds,** the status light remains on **solid yellow** for the first **11** seconds and then turns to **solid green**. In the meantime, the SOC power indicators remain on **solid blue** based on the battery packs' actual battery capacity. At this point, release the button.
- **In the event that the user wishes to increase or reduce the battery packs,** the system must be turned off. After completing the capacity expansion or reduction, press and hold the POWER button for more than 15 seconds to reassign each battery pack in communication loop a unique address.
- **In the event that the inverter purchased by the user is one of the models specified in *PYLON CANBUS Protocol*,** the user must continuously press the POWER button 3 times within 10 seconds to power on the battery. After a successful power-on,
 - a. If the battery is running properly, it will be charging all the time.
 - b. If there is any fault, the battery will power off first and then automatically power on again after such a fault has been resolved.
- A system problem may be encountered while pressing the button frequently. The user may need to wait at least 10 seconds and then try again.

 **WARNING!**

- After the battery pack powers off, there will still be the remaining electricity and heat which may cause electric shocks and body burns. Please wear personal protective equipment (PPE) and begin servicing the battery five minutes after power off.

11 Troubleshooting and Maintenance

11.1 Troubleshooting

This section contains information and procedures for resolving possible problems with the rechargeable battery and provides the troubleshooting tips to identify and solve most problems that may occur. Please conform the state of the indicators to check the status of the T-BAT system, check the warning or fault information via the monitoring software on the inverter, and read the suggested solutions below when error occurs.

In case of the following circumstances, e.g. voltage or temperature exceeds the limit specified, a warning state will be triggered.

The battery management system (BMS) of the T-BAT system will periodically report its operating state to the inverter. Therefore, when a warning is reported, the inverter will stop working immediately.

Contact SolaX Customer Service for further assistance. Please be prepared to describe the details of your system installation and provide the model and serial number of the rechargeable battery.

Error Code	Fault	Diagnosis and Solution
Cell Overvoltage	Battery cell overvoltage fault	Battery (cell) overvoltage: <ul style="list-style-type: none">• Tap "Power Off" on the inverter screen until the fault is rectified.• Contact the after-sales personnel of our company.
Cell Undervoltage	Battery cell undervoltage fault	Battery (cell) undervoltage: <ul style="list-style-type: none">• Make sure that the inverter is connected to the grid and that there is successful communication between the battery and inverter to ensure that the battery is charged.• Contact the after-sales personnel of our company.
High Cell Vol Diff	The pressure difference between cells in the battery is too large	The pressure difference between cells in the battery is too large: <ul style="list-style-type: none">• Restart the BMS.• Contact the after-sales personnel of our company.

Error Code	Fault	Diagnosis and Solution
HVB Overvoltage	Total voltage overvoltage fault	<p>Total voltage overvoltage:</p> <ul style="list-style-type: none"> • Tap "Power Off" on the inverter screen until the fault is rectified. • Contact the after-sales personnel of our company.
HVB Undervoltage	Total voltage undervoltage fault	<p>Total voltage undervoltage:</p> <ul style="list-style-type: none"> • Make sure that the inverter is connected to the grid and that there is successful communication between the battery and inverter to ensure that the battery is charged. • Contact the after-sales personnel of our company.
Overtemp Fault	High temperature of the BMS	<p>The temperature of the BMS is too high:</p> <ul style="list-style-type: none"> • Cool down the BMS to normal temperature, and then restart it. • Contact the after-sales personnel of our company.
Low Temp Fault	Low temperature of the BMS	<p>The temperature of the BMS is too low:</p> <ul style="list-style-type: none"> • Warm up the BMS to normal temperature, and then restart it. • Contact the after-sales personnel of our company.
Self-check Fault	Self-test fault of the BMS	<p>Self-test fault of the BMS:</p> <ul style="list-style-type: none"> • Restart the BMS. • Contact the after-sales personnel of our company.
Precharge Fail	BMS precharge failure fault	<p>External short circuit of the BMS:</p> <ul style="list-style-type: none"> • Check the external connection and restart the BMS. • Contact the after-sales personnel of our company.
Temp Sample Fault	Temperature sampling anomaly	<p>Temperature sampling anomaly:</p> <ul style="list-style-type: none"> • Restart the BMS. • Contact the after-sales personnel of our company.
System Fault	Slave control of abnormal current exists in the system	<p>Slave control of abnormal current exists in the system:</p> <ul style="list-style-type: none"> • Restart the BMS. • Contact the after-sales personnel.

Error Code	Fault	Diagnosis and Solution
Didchrg Overcurrent	Discharge overcurrent of BMS	Discharge overcurrent of BMS: <ul style="list-style-type: none"> • Restart the BMS. • Contact the after-sales personnel of our company.
Chrg Overcurrent	Overcurrent charging of BMS	Overcurrent charging of BMS: <ul style="list-style-type: none"> • Restart the BMS. • Contact the after-sales personnel of our company.
AFE Comm Fault	AFE communication fault	AFE communication loss: <ul style="list-style-type: none"> • Contact the after-sales personnel of our company.
Mid Comm Fault	The communication between the master and slave is abnormal	The communication between the master and slave is abnormal: <ul style="list-style-type: none"> • Restart the BMS. • Contact the after-sales personnel of our company.
Voltage Sensor Fault	Voltage sensor fault	Voltage sampling fault of the BMS: <ul style="list-style-type: none"> • Restart the BMS. • Contact the after-sales personnel of our company.
ID Duplicate	The slave controller with the same number exists in the system.	The slave controller with the same number exists in the system: <ul style="list-style-type: none"> • Restart "Black Start". • Contact the after-sales personnel of our company.
Current Sensor Fault	Current sensor fault	Current sampling fault of the BMS: <ul style="list-style-type: none"> • Restart the BMS. • Contact the after-sales personnel of our company.
Power Line Open	The power cable is not properly plugged in.	Improper connection of the power cable: <ul style="list-style-type: none"> • Rewire the power cables. • Contact the after-sales personnel of our company.
Flash Error	Flash fault	Flash fault: <ul style="list-style-type: none"> • Contact the after-sales personnel of our company.

Error Code	Fault	Diagnosis and Solution
AFE Protect Fault	AFE self-protection failure	AFE self-protection failure: <ul style="list-style-type: none"> • Contact the after-sales personnel of our company.
Charge Request Fault	Charging request not responded	Inverter does not respond the charging request. <ul style="list-style-type: none"> • Restart the BMS or the inverter. • Contact the after-sales personnel of our company.
BMS_LOST	Communication loss of the BMS	Communication loss of the BMS: <ul style="list-style-type: none"> • Ensure that the communication cable is properly connected. • Contact the after-sales personnel of our company.
ALM_ID_BAT_TYPR_CFG_ERR	Error of battery type	Error of battery type: <ul style="list-style-type: none"> • Check whether the communication cable is properly connected after shutting down all the battery packs, and then restart Black Start.
ALM_ID_BATT_VOLT_HIGH	BMS overvoltage	Overvoltage of a single battery pack: <ul style="list-style-type: none"> • Contact the after-sales personnel of our company.
ALM_ID_BAT_BMS_CELL_FAULT	Battery cell fault of the BMS	Battery cell fault of the BMS: <ul style="list-style-type: none"> • Check the fault carefully. • Contact the after-sales personnel of our company.
ALM_ID_BAT_BMS_COMM_FAULT	BMS communication fault	BMS communication fault: <ul style="list-style-type: none"> • Check the fault carefully. • Contact the after-sales personnel of our company.
ALM_ID_BAT_CURR_HIGH	Battery current too high	Too much current is drawn by a load: <ul style="list-style-type: none"> • Decrease the load power • Contact the after-sales personnel of our company.
ALM_ID_BAT_SOC_LOW	Low SoC	Low SoC: <ul style="list-style-type: none"> • Check the fault carefully. • Contact the after-sales personnel of our company.

11.2 Maintenance

Regular maintenance is required for the rechargeable battery. Please pay attention to the following precautions for expressing the optimum device performance. More frequent maintenance service is needed in the worse work environment. Please make records of the maintenance.

Precautions

- If the ambient temperature for storage is between 30°C and 50°C (86°F to 122°F), please recharge the battery packs at least once every 6 months.
- If the ambient temperature for storage is between -20°C and 30°C (-4°F to 86°F), please recharge the battery packs at least once every 12 months.
- For the first installation, the interval among manufacture dates of battery packs shall not be exceed 3 months.
- If a battery pack is replaced or added for capacity expansion, each battery's SOC should be consistent. The max. SOC difference should be $\pm 5\%$.
- If users want to increase their battery system capacity, please ensure that the SOC of the existing system capacity is about 40%. The manufacture date of the new battery pack shall not exceed 6 months. If the manufacture date of the new one exceeds 6 months, please charge it to around 40%.

WARNING!

- Only qualified person can perform the maintenance for the rechargeable battery.
- Only use the spare parts and accessories approved by SolaX for maintenance.

12 Decommissioning

12.1 Disassembling the Battery

! WARNING!

- Before unplugging the cables, ensure that your hands are dry and free from moisture. This will help prevent electrical shock and ensure a secure grip on the plug.
- When disassembling the battery, strictly follow the steps as below.

NOTICE!

- No matter how many battery packs are installed, the unplugging procedure is the same. For details, refer to the following steps.

Step 1: Press the POWER button to shut down the system before unplugging.

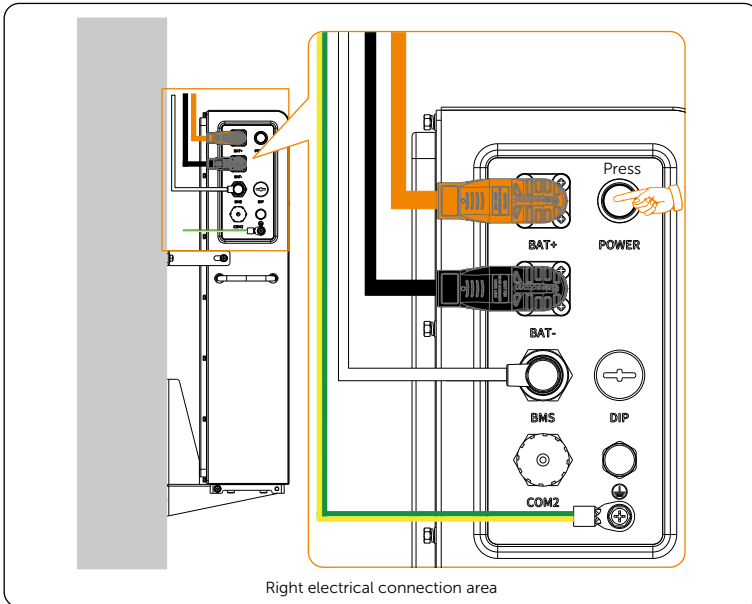

Figure 12-1 Pressing power button

Step 2: Hold down two lock buttons on both sides of the connector firmly to unplug the power cable. Avoid pulling on the cable itself, as this can potentially damage the cable and the port on the battery pack.

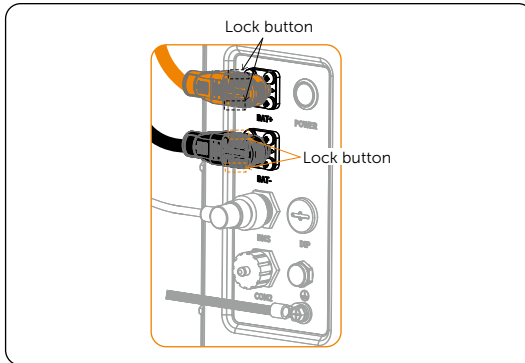

Figure 12-2 Unplugging power cables

Step 3: Remove the communication cable.

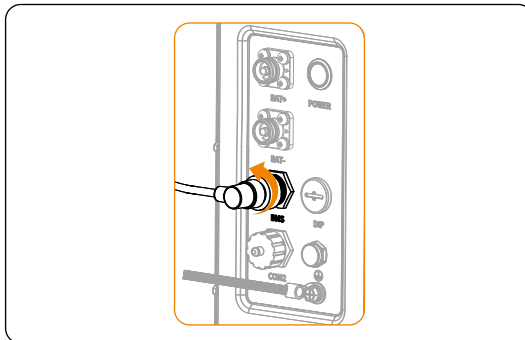

Figure 12-3 Removing communication cable

Step 4: Unscrew the screws counter-clockwise to remove the grounding cable.

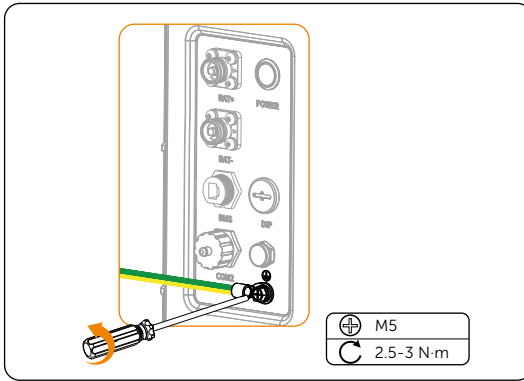

Figure 12-4 Removing grounding cable

12.2 Packing

- Load the battery pack into the original packing material if possible.
- If the original packing material is not available, you can also use the packing material which meets the following requirements:
 - » Suitable for the weight of product.
 - » Easy to carry.
 - » Be capable of being closed completely.

12.3 Disposing of the Rechargeable Battery

Please dispose of the rechargeable battery or accessories in accordance with the disposal regulations for electronic waste which is applied at the installation site.

13 Technical Data

Parameter Display



Battery pack	TP-LD53
Nominal Voltage (Vdc)	51.2
Operating Voltage (Vdc)	45-58
Nominal Capacity (Ah) ¹	104
Nominal Energy (kWh) ¹	5.32
Usable Energy 90% DOD (kWh) ²	4.7
Max. Output Current (A) ³	100
Peak Charge/Discharge Current (A) ⁴	200 (10 seconds)
Battery Round-trip Efficiency (0.2C, 25°C)	95%
Cycle Life 90% DOD (25°C)	6000 cycles
Charge Temperature	0°C ~ 53°C
Discharge Temperature	-20°C ~ 53°C
Storage Temperature	30°C ~ 50°C (6 months); -20°C ~ 30°C (12 months)
Ingress Protection	IP65
Protection Class	I

NOTICE!



1. Test conditions: 100% DOD, 0.2 C charge & discharge @ +25°C.
2. System usable energy may vary with inverter different setting.
3. Discharge: In case of battery cell's temperature range of -20°C ~ 10°C and 45°C ~ 53°C, the discharge current will be reduced;
Charge: In case of battery cell's temperature range of 0°C ~ 25°C and 45°C ~ 53°C, the charge current will be reduced. Product charge or discharge power depends on the actual temperature of the battery cell.
4. The battery can only be discharged and cannot be charged when the battery cell's temperature range is between -20°C and 0°C.

Contact Information



UNITED KINGDOM

 Unit C-D Riversdale House, Riversdale Road, Atherstone, CV9 1FA
 +44 (0) 2476 586 998
 service.uk@solaxpower.com

TURKEY

 Fevzi Çakmak mah. aslim cd. no 88 A Karatay / Konya / Türkiye
 service.tr@solaxpower.com



USA

 3780 Kilroy Airport Way, Suite 200, Long Beach, CA, US 90806
 +1 (408) 690 9464
 info@solaxpower.com

POLAND

 WARSAW AL. JANA P. II 27. POST
 +48 662 430 292
 service.pl@solaxpower.com



ITALY

 +39 011 19800998
 support@solaxpower.it





PAKISTAN

 service.pk@solaxpower.com





AUSTRALIA

 21 Nicholas Dr, Dandenong South VIC 3175
 +61 1300 476 529
 service@solaxpower.com.au



GERMANY

 Am Tullnaupark 8, 90402 Nürnberg, Germany
 +49 (0) 6142 4091 664
 service.eu@solaxpower.com
 service.dach@solaxpower.com



NETHERLANDS

 Twekkeler-Es 15 7547 ST Enschede
 +31 (0) 8527 37932
 service.eu@solaxpower.com
 service.bnl@solaxpower.com

SPAIN

 +34 9373 79607
 tecnico@solaxpower.com

BRAZIL

 +55 (34) 9667 0319
 info@solaxpower.com

SOUTH AFRICA

 service.za@solaxpower.com



SolaX Power Network Technology (Zhejiang) Co., Ltd.

Add.: No. 278, Shizhu Road, Chengnan Sub-district, Tonglu County,
Hangzhou, Zhejiang, China
E-mail: info@solaxpower.com

