

AC Switching Cabinet

X3-PCAB-750kW-A

Installation Manual

Version 4.0

www.solaxpower.com



eManual in the QR code or at <http://kb.solaxpower.com/>

Table of Contents

Safety.....	1
Preparation before Installation	6
Mechanical Installation.....	14
Electric Connection	18
System Power-on.....	35
System Power-off.....	37
LED Indicators	40
Technical Data.....	41

Safety

General Notice

1. Contents may be periodically updated or revised. SolaX reserves the right to make improvements or changes in the product(s) and the program(s) described in this manual without the prior notice.
2. The installation, maintenance and grid-related setting can only be performed by qualified personnel who:
 - Are licensed and/or satisfy state and local jurisdiction regulations;
 - Have good knowledge of this manual and other related documents.
 - A medium-voltage operator is required to obtain any Certifications for High-voltage Electrician.
3. Before installing the device, carefully read, fully understand and strictly follow the detailed instruction of the user manual and other related regulations. SolaX shall not be liable for any consequences caused by the violation of the storage, transportation, installation, and operation regulations specified in this document and the user manual.
4. Use insulated tools when installing the device. Individual protective tools must be worn during installation, electrical connection and maintenance.
5. Please visit the website www.solaxpower.com of SolaX for more information.

Safety Instruction

For safety reasons, installers are responsible for familiarizing themselves with the contents of the manual and all warnings before performing installation.

Descriptions of Labels



CE mark of conformity



TUV certification



Grounding point



Additional grounding point



Caution, risk of danger



Caution, hot surface



Caution, risk of electric shock



Read the enclosed documentations.



Do not dispose of the cabinet together with household waste.

 **DANGER!**

- According to the local laws and regulations related to high-altitude work, operators must wear PPE, e.g., a helmet, safety belt, or waist harness, when they work at heights, while the other end of the harness must connect to a secure structure to prevent fall incidents.

 **DANGER!**

- Please make sure that the unit is free from any damage before the electrical connection.
- Do not modify, change, or dismantle the device, do not change the power-on and power-off sequences and the installation procedure written in the document, and please properly and correctly operate it.
- Do not power on the device during installation. Otherwise, it may cause a fire, personal injury, or device damage.
- Must remove earrings, rings, bracelets, watches, and any other metal jewelry before operation, to avoid electrical shock, burns, or even death.
- During operation, special insulated tools must be used to avoid electric shock or short circuit failure. The insulated tools' voltage ratings must exceed the system voltage ratings. Please refer to "Technical Data" for system information.

 **WARNING!**

EMC

- This is a class A device. Operating this device in a residential area may cause radio interference, and the user might need to take appropriate measures in such cases.

 **WARNING!**

- Please prepare tools that meet the requirements before installation, and check the number of tools after installation, to avoid leaving them inside the equipment.
- Please ensure that the cabinet has been thoroughly secured before operating it. Otherwise, it may cause personal injury or equipment damage due to tilting or collapsing the cabinet.
- Please ensure that the cabinet's vents and cooling system are working properly when it is running. If the vents are blocked, it will lead to overheating, and even equipment damage or fire hazard.
- Please ensure that the cabinet's vents and cooling system are kept away from heat sources.
- Do not drill holes in the device to avoid equipment failure.
- If the circumstances that may cause personal injury or equipment failure occur, such as, fluid flowing into the equipment, stop operation and power off immediately. Otherwise, it may cause a short circuit or damage.
- Do not open the cabinet doors on a rainy or high humid day ($\geq 80\%$ humidity). If the doors have to be opened on such days, please take proper protective measures.

 **WARNING!**

- Overvoltage protection with surge arresters should be provided when the PV system is installed. The grid connected inverter is fitted with SPDs on both PV input side and MAINS side.
- Please consult professionals before installing SPDs.
- Make sure that the input DC voltage does not exceed the maximum DC input voltage specified for the inverter. Overvoltage can cause irreversible damage to the inverter, and such damage is not covered by the warranty.
- PV modules should have an IEC61730 class A rating.

 **WARNING!**

- Operators must wear PPE while installation and maintenance of the device.
- Never connect or disconnect the AC and DC connector while the PCS is running.
- Prior to conducting any maintenance, turn off the AC and DC power and disconnect them from the PCS. Wait for 15 minutes to fully discharge the energy.
- Avoid touching the PCS while it is running, as it becomes hot during operation and may cause personal injuries.

 **WARNING!**

- Please wear PPE, such as, protective clothing, insulating shoes, goggles, safety helmets, insulating gloves, etc., when conducting electrical wiring.
- Do not touch the power supply equipment directly, or through conductors or damp objects.
- Do not touch the parts of the equipment of which warning signs are attached, to avoid personal injury or device damage.

 **WARNING!**

- When the system is operating off-grid, do not close the QF-GRID breaker without permission.

 **CAUTION!**

- Do not use a straight ladder. When electrical work is involved, a wooden ladder or an insulated ladder shall be used.
- The equipment shall not be used to provide a backup power source in the following circumstances:
 - a. Equipment related to life;
 - b. Sensitive precision instruments;
 - c. Home appliances will be faulty in the case of a power failure during operation.
- Do not power on the equipment until it has been installed and confirmed by professionals.
- In the event of a fire, evacuate immediately and call the local fire services.

 CAUTION!

- Make sure that children are supervised to prevent them from playing with the inverter.
- Pay attention to the weight of the inverter and handle it properly to avoid personal injuries.

 CAUTION!

- Do not power on the device until it has been installed and confirmed by professionals.
- In the event of a fire, evacuate immediately and call the local fire services.

NOTICE!

- The signs and messages on the labels and nameplates attached to the device need to be visible and clear.

NOTICE!

- Please operate according to the safety code for power station.
- Before installation, it is necessary to set up temporary safety fences or warning lines and hang warning signs in the operation area, to prohibit non-staff from entering here.
- Please make sure that the equipment and its associated switches are off before connecting and disconnecting power cables.
- Please check whether the protective housing and insulating sleeve for an electrical component have been installed correctly after finishing installation, to avoid electric shock.
- Must turn off the output switch of the power supply equipment when maintaining its electrical terminal device and power distribution device.
- If the device is required to be powered off during troubleshooting and diagnosis, please do as the following procedure: power off > electricity testing > connecting grounding cable > hanging warning signs and setting up guardrails.
- Must hang up "Do Not Switch On" warning signs on the relevant switches or circuit breakers before completing maintenance, to prevent power connection. Do not switch on before the fault is solved.
- Do not use water, alcohol, oil, or other solvents when cleaning electrical components inside and outside the device.

NOTICE!

Grounding Requirements:

- The device's grounding impedance shall meet the requirements of local electrical safety standards.
- The equipment shall be permanently connected to a grounding wire within the building's electrical system. Please check whether the device is reliably grounded before operation. The grounding cable should be removed last while dismantling and maintaining the device.
- Do not start the device if it is not fitted with a grounding conductor.
- All acts against the grounding conductor are prohibited.
- If the device is equipped with a three-pronged socket, make sure that the ground prong is reliably grounded.
- For the device that may generate large contact currents, please make sure that the grounding terminal on the housing has been grounded before powering on, to avoid electric shock.

Cable Requirements:c

- When deciding the wire diameter, and connecting or wiring cables, follow the local laws, regulations, and codes to ensure safety.
 - When external conditions (e.g., placement method, ambient temperature, etc.) change, the cable type must be verified according to IEC-60364-5-52 or local laws, regulations and standards. For instance, whether the cable's current-carrying capacity meets the requirements.
 - Before connecting power cables, please make sure that the cable labels are correctly labelled and the cable terminals are well insulated.
 - Do not loop and twist cables while conducting electrical wiring. If the length of the power cable is not enough, please replace it instead of joining or welding. Ensure that all the cables of the correct type and size are fully connected and well insulated, and the edges of cable slots and crossing holes are smooth.
-
- It is recommended to bundle similar cables with cable ties, to ensure that the inside of the device is neat and tidy and to avoid cable jacket damage.
 - Please use fireproof mud to seal the threading openings immediately after finishing wiring, to avoid the entry of water vapour or small animals.
 - Cables should be kept away from heaters or other heat sources, because a high temperature environment may result in aging and damage to cable insulation.

Preparation before Installation

Installation Site



Installation Site	Distance
Distance from the device to the coast	> 2000 m
Distance from the device to the high heavily polluted area, for instance, smelting plant, coal mine, thermal power plant, etc.	> 1500 m
Distance from the device to the moderately polluted area, for instance, chemical plant, rubber plant, electroplate factory, etc.	> 1000 m
Distance from the device to the lightly polluted area, for instance, food factory, leather factory, heating boiler, slaughter house, dumping site, sewage treatment plant, etc.	> 500 m

Forklift Requirement

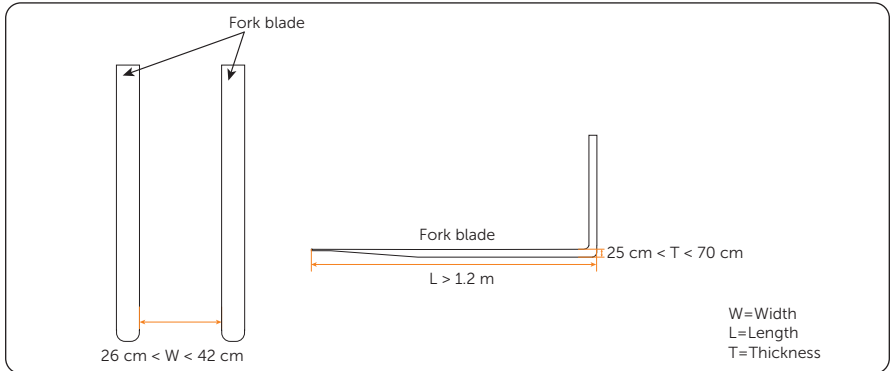

Installation Carrier

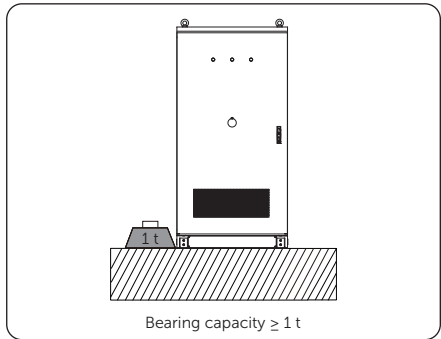
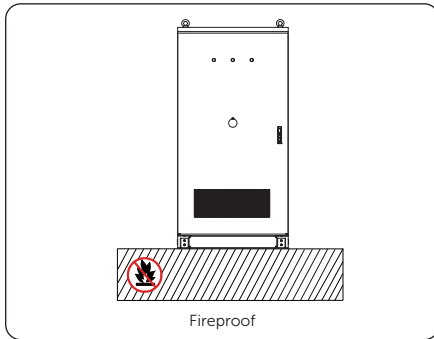

Dimension and Installation Foundation

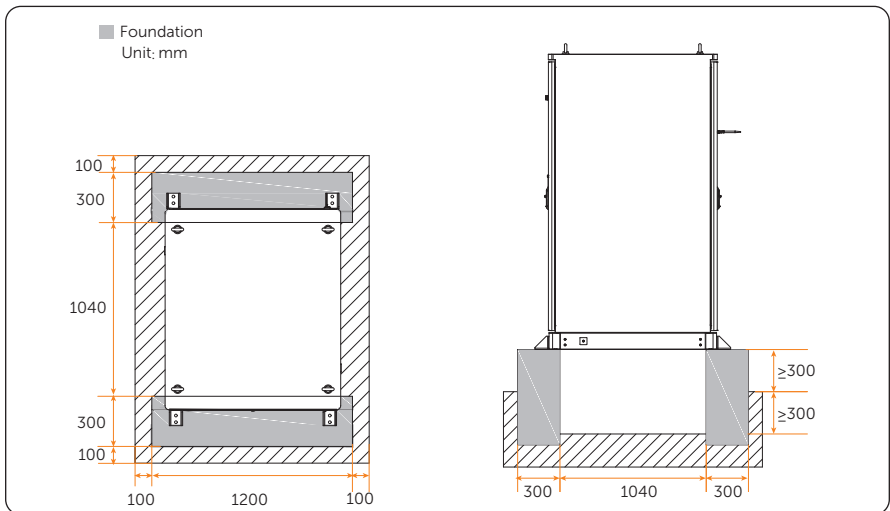
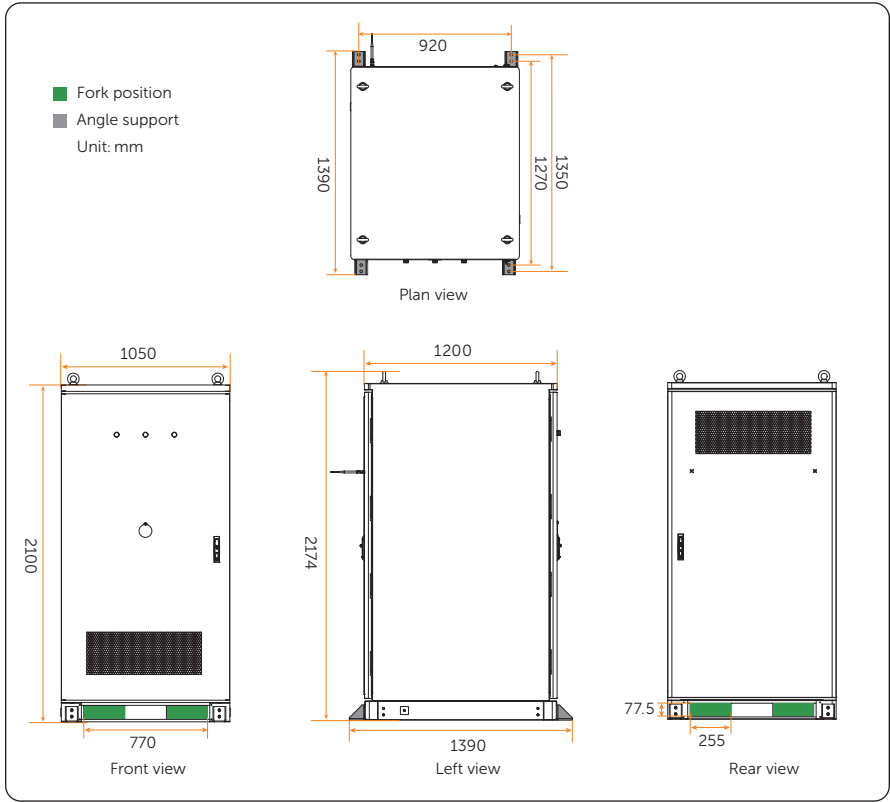

NOTICE!

- When placed side by side with SolaX energy storage cabinets, the clearance between the switching cabinet and SolaX cabinets should be at least 50 mm;
- When placed side by side with other objects such as firewalls, the clearance should be at least 400 mm;

Clearance requirements for single cabinet:

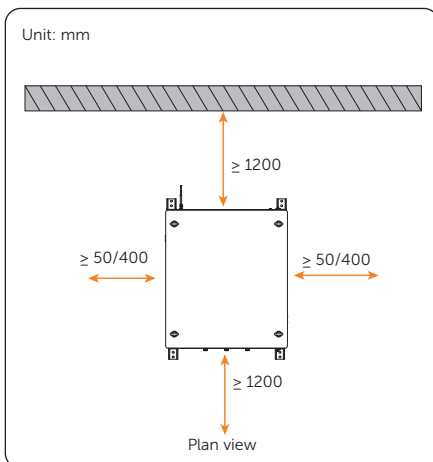
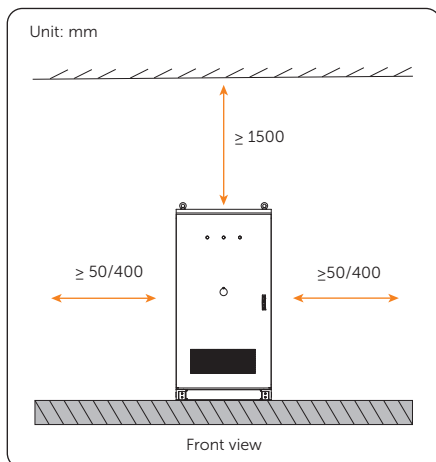

Clearance requirements for multiple cabinets:

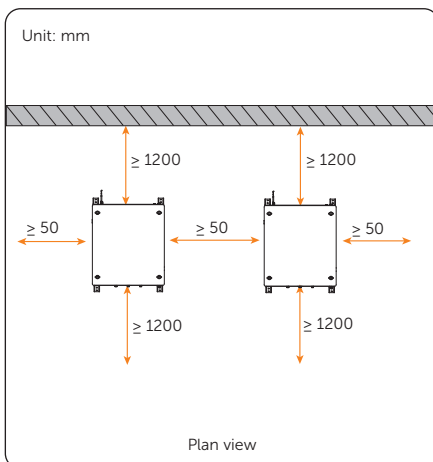
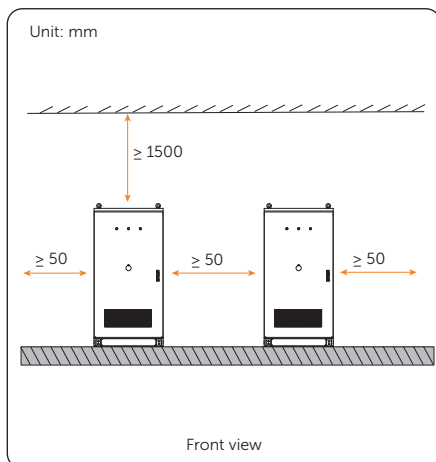





Installation Tools

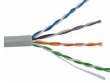

Additionally Required Materials

No.	Required material	Cable Type	Conductor Cross-section	Quantity
1	Grid cable	 4-core copper cable	≥ 240 mm ²	3 groups

No.	Required material	Cable Type	Conductor Cross-section	Quantity
2	Load cable 	4-core copper cable	$\geq 240 \text{ mm}^2$	3 groups
3	PCS cable 	4-core copper cable	$\geq 35 \text{ mm}^2$ (for AELIO system)	10 groups
			$\geq 70 \text{ mm}^2$ (for TRENE system)	6 groups
4	PE wire 	Conventional yellow and green cable	$\geq 120 \text{ mm}^2$ (for grid, load and cabinet grounding)	/
5	Network cable 	Network cable CAT5E	/	/
6	COM cable 	Shielded twisted-pair cable	0.5 mm^2	/

NOTICE!

When used with AELIO system, the total communication distance through network cables among the cabinets shall be within 70 meters to ensure stable data transmission. When used with TRENE system, the total communication distance through network cables among the cabinets shall be within 50 meters to ensure stable data transmission.

No.	Required material	Type (Recommended)	Quantity	Description
7		TLK240-12	24	For connecting the power cables of the grid and load
8		TLK120-12	2	For cabinet grounding
9	Ring terminal 	TLK120-8	6	For load grounding
10		TLK35-8	24	For PCS connection (35 mm ² power cable in AELIO system)
11		TLK70-8	24	For PCS connection (70 mm ² power cable in TRENE system)

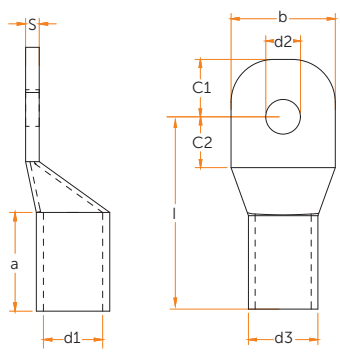

Ring terminal dimensions requirements

Terminal type	Dimensions (mm)								
	S	a	b	C1	C2	d1	d2	d3	l
TLK 240-12	4.8	35.0	39.0	21.5	19.0	21.0	13.0	26.0	72.0
TLK 120-12	4.3	26.0	28.0	14.0	14.0	15.0	13.0	19.5	51.0
TLK 120-8	4.3	26.0	28.0	14.0	14.0	15.0	8.4	19.5	51.0
TLK 35-8	3.2	17.0	17.0	10.0	10.0	8.5	8.4	12.0	34.0
TLK 70-8	4.2	21.0	23.0	10.0	10.0	12.0	8.4	16.5	34.0

Packing List

Procedure to Take Out the Accessory Kit (At the Rear Door)

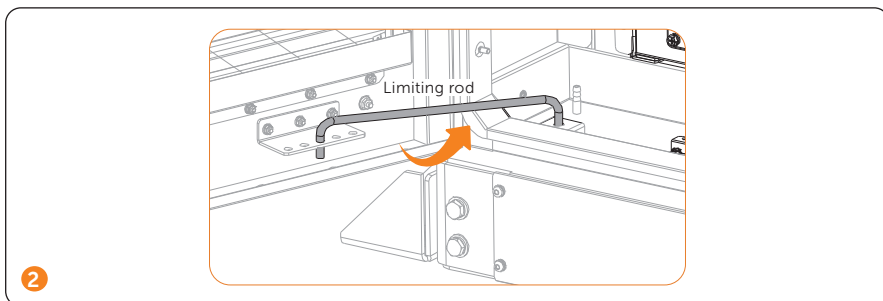
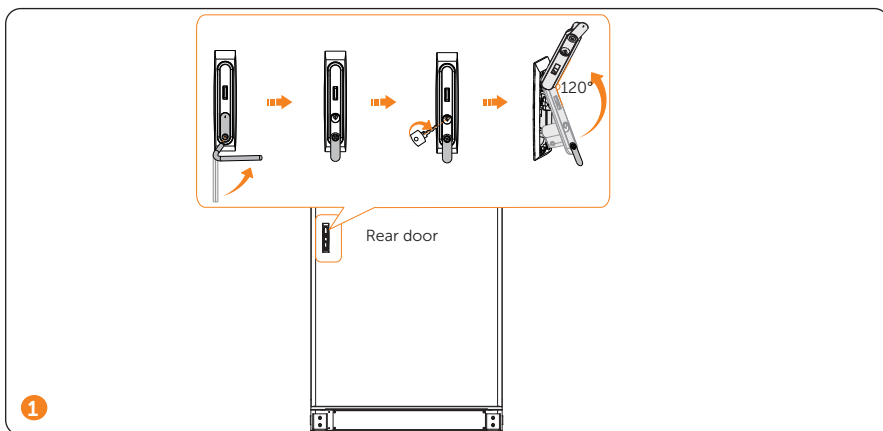

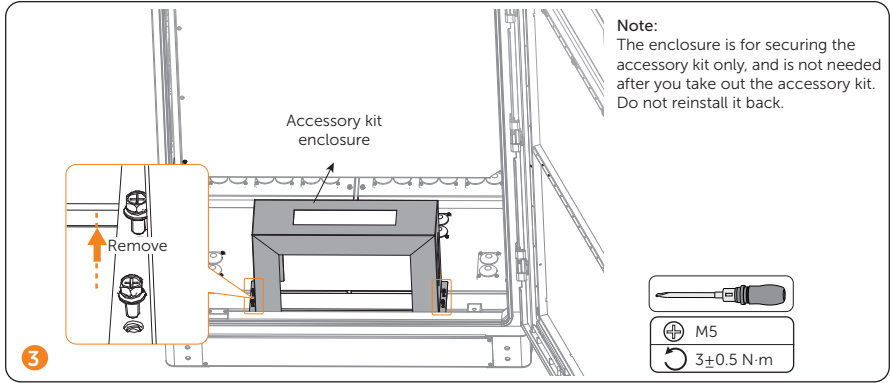

NOTICE!

The *Installation Manual* is placed in the file pocket on the front door of the cabinet.

Packing List

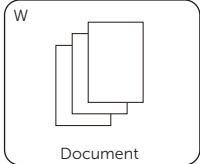
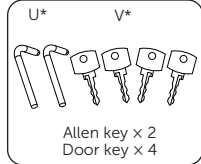
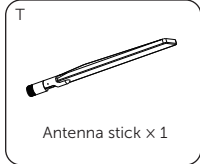
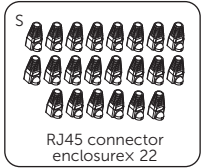
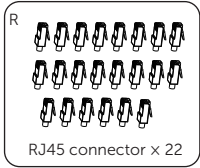
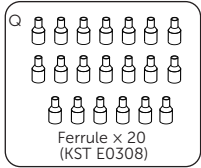
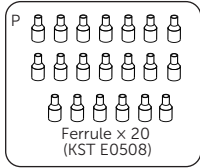
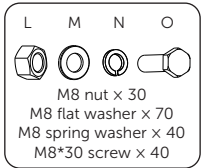
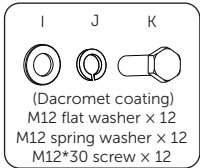
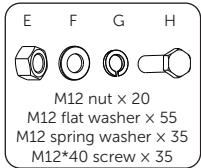
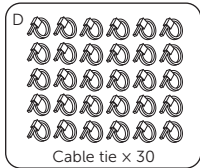
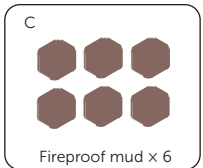
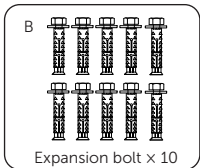
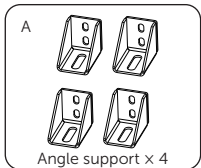
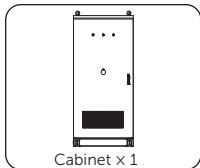

NOTICE!

- The accessory kit is placed under the sheet metal enclosure at the rear of the cabinet.
- U* and V* are collected in a bunch, and are inserted into the door lock upon delivery.

Mechanical Installation

Removing the Wooden Pallet

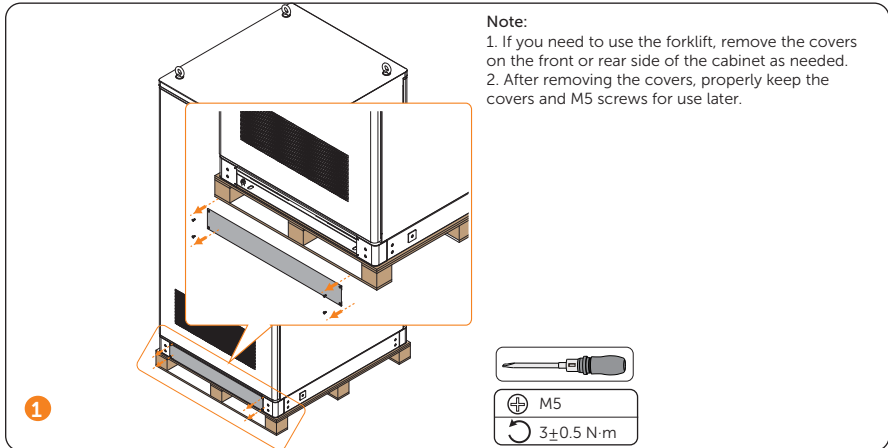

1

Note:

1. If you need to use the forklift, remove the covers on the front or rear side of the cabinet as needed.
2. After removing the covers, properly keep the covers and M5 screws for use later.

+

M5

3±0.5 N·m

Remove the screws for securing the pallet.

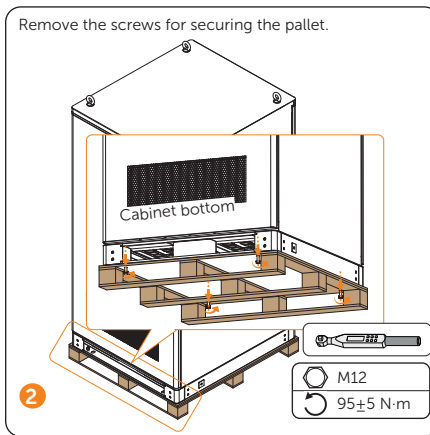

Cabinet bottom

2

+

M12

95±5 N·m

Unload the cabinet from the pallet.

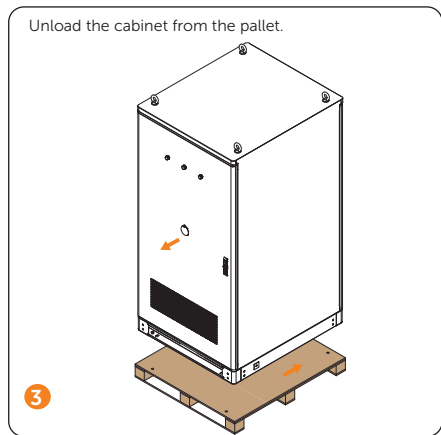

3

Using the Crane/Forklift

Select either equipment to place the cabinet on the defined installation site.

Crane position

NOTICE!

- Before threading ropes, check and make sure the eye bolts are securely installed on the top of the cabinet.

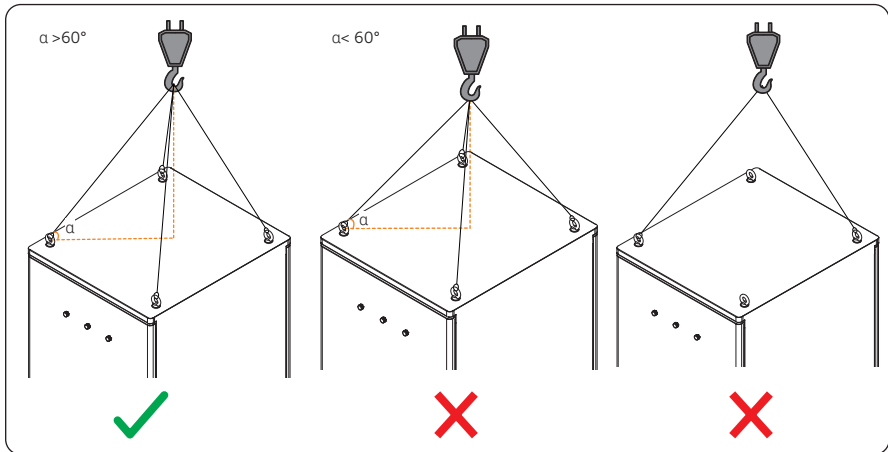

Fork Position

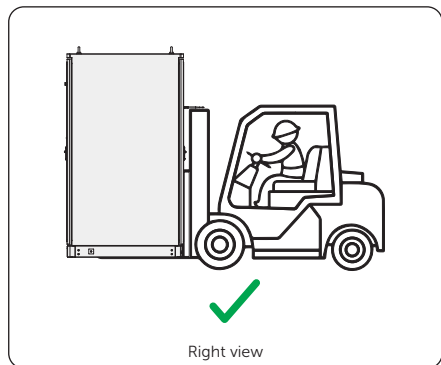
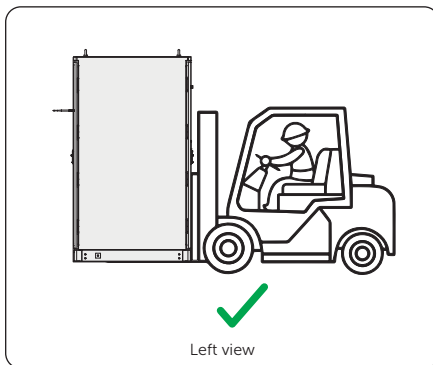

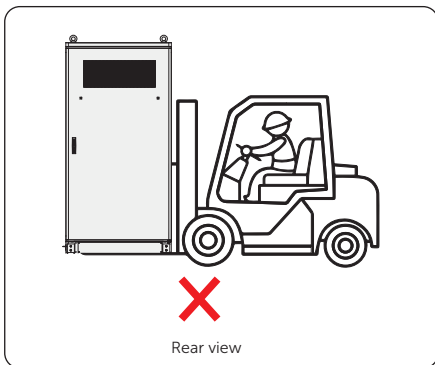
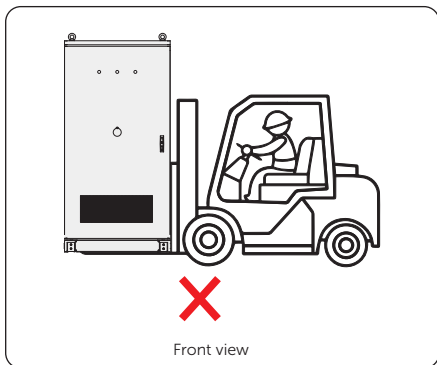

Installation of Angle support and Cover

Aligning

1

NOTICE!

- Pay attention to the direction of the angle support. The side with two holes should be upright, and the side with a long hole should be placed against the foundation.

Drawing holes

≥ 40 mm

2

$\varnothing 18$ mm

95~105 mm

90°

3

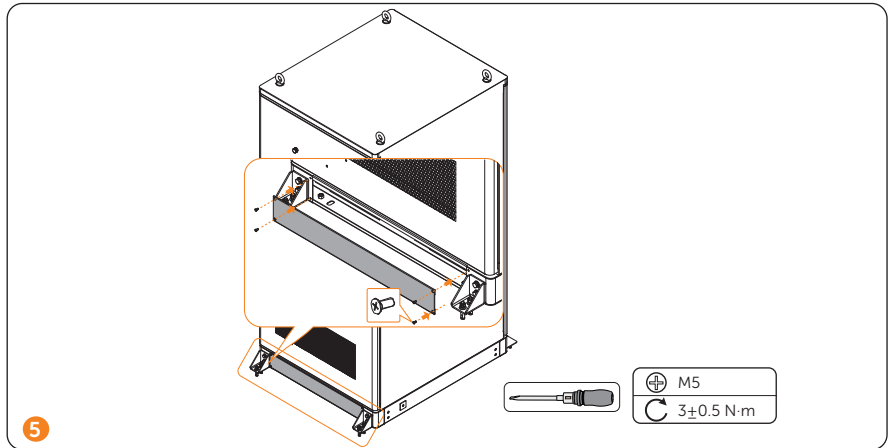
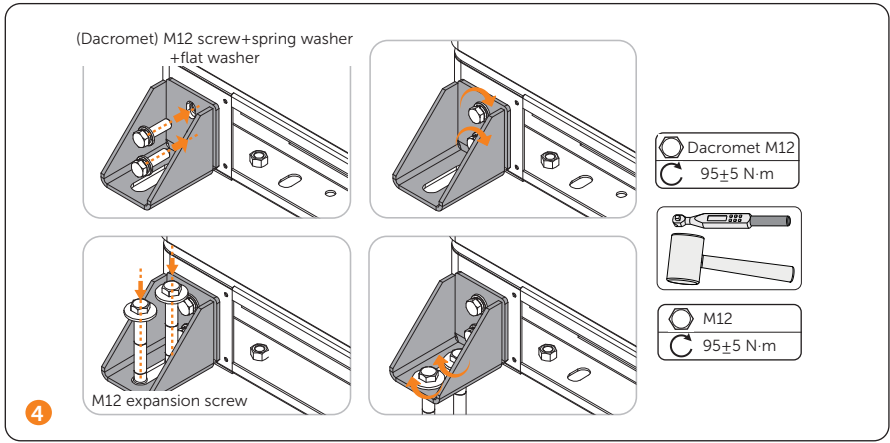

Installation of Antenna

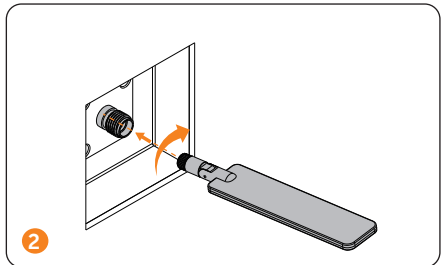
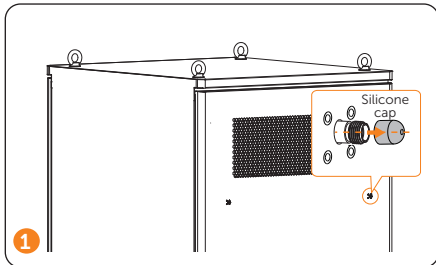

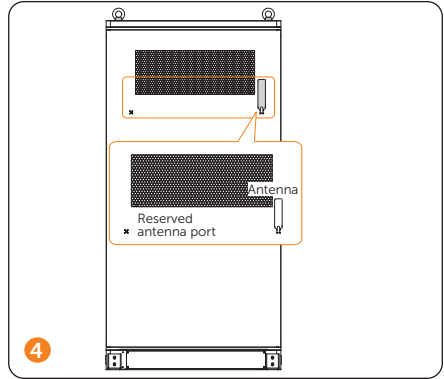
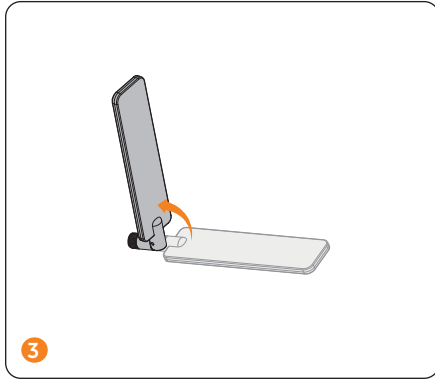

NOTICE!

- An additional antenna port is available. The antenna connection procedure of this terminal is the same as the designated antenna port.
- Keep the sealing caps on if the antenna ports are not used.

Electric Connection

Position of the Wired Parts

The general location of the wiring modules are as follows:

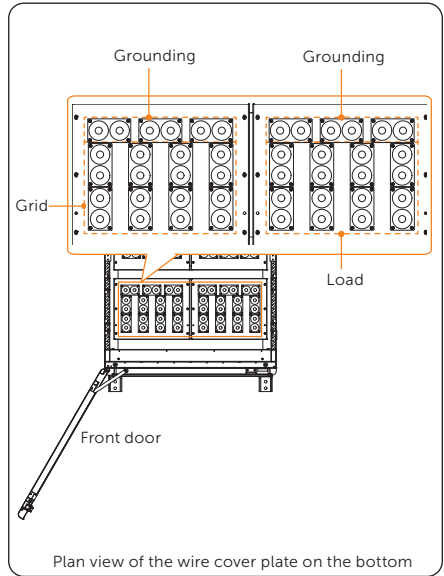
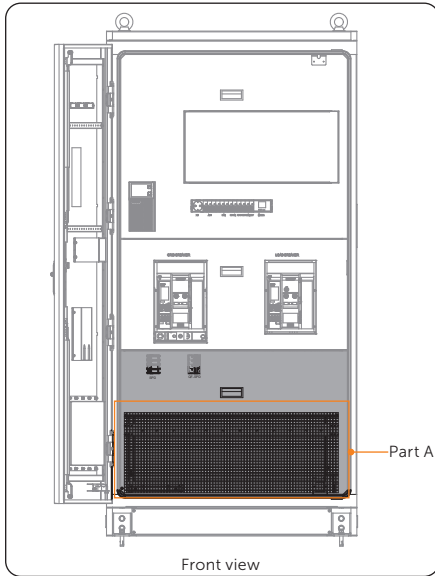

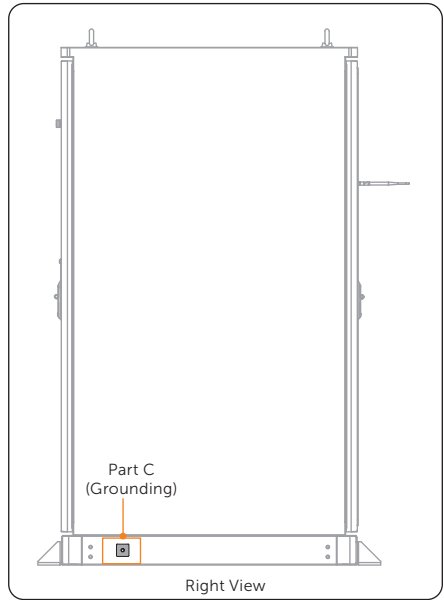
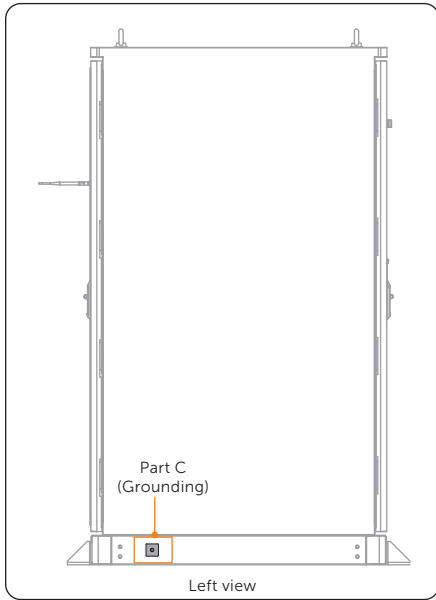
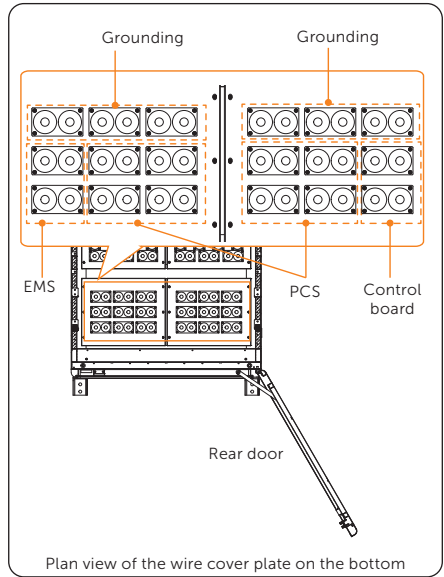
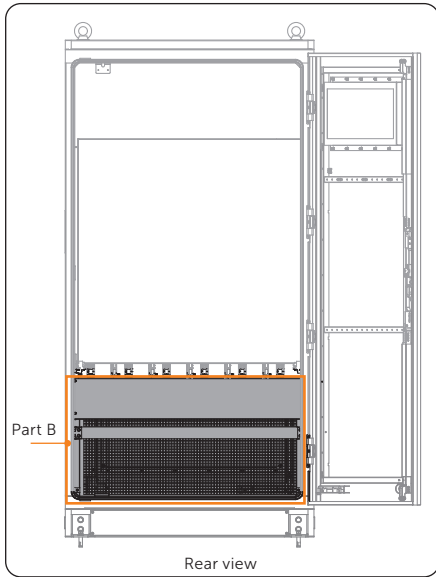

Preparing the PE cable and power cable

NOTICE!

- This section introduces the steps to make PE cable and power cable for grid connection, load connection and PCS connection of the cabinet. These connections share the same procedure for making cables.
- For grid, load and PCS connection, the PE cable must be connected first before connecting the power cables.

Preparing PE cable

The cable specification and strip length of the PE cables vary depending on the different connections. See the table below for details.

Connection Type	Cable Specification	Specification of Heat Shrink Tube	Terminal Type (Recommended)	Jacket Stripe Length
Cabinet	120 mm ²	Diameter: Ø20-25 mm Length: 70-80 mm	TLK120-12	30 mm
Load			TLK120-8	

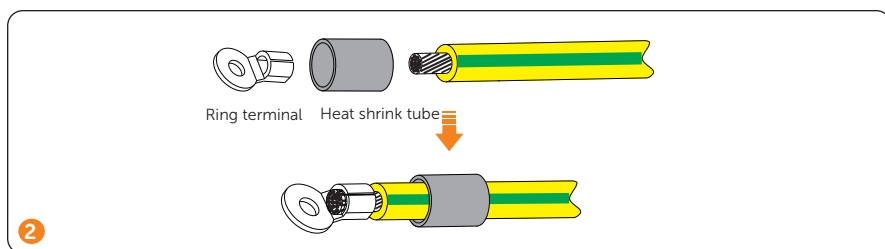
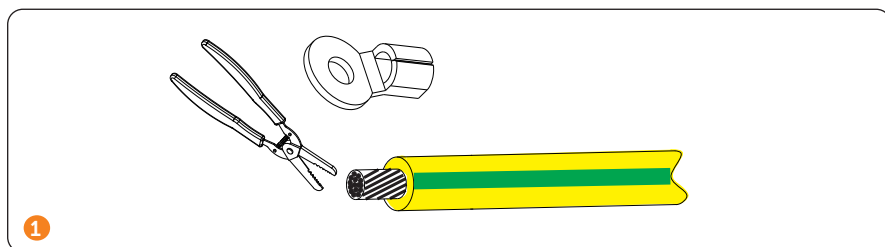

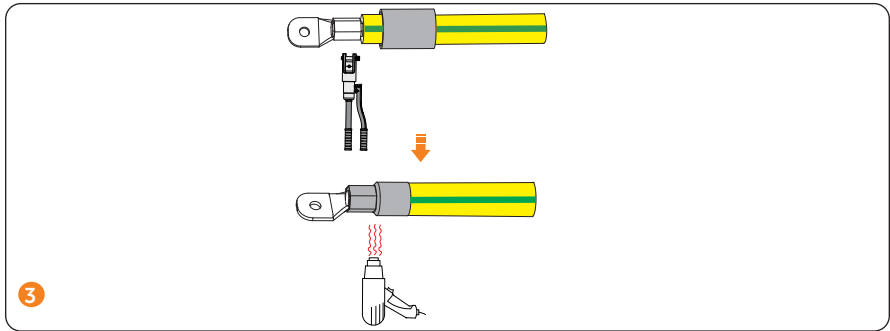

Preparing the Power cable

Connection Type	Ring Terminal Type	Specification of Heat Shrink Tube	Jacket Stripe Length	Insulation Stripe Length
Grid Load	TLK240-12	Diameter: Ø30-35 mm Length: 80-90 mm	700-800 mm	40 mm
PCS (TRENE)	TLK70-8	Diameter: Ø20-25 mm Length: 60-70 mm	500-600 mm	25 mm
PCS (AELIO)	TLK35-8	Diameter: Ø15-20 mm Length: 50-60 mm		20 mm

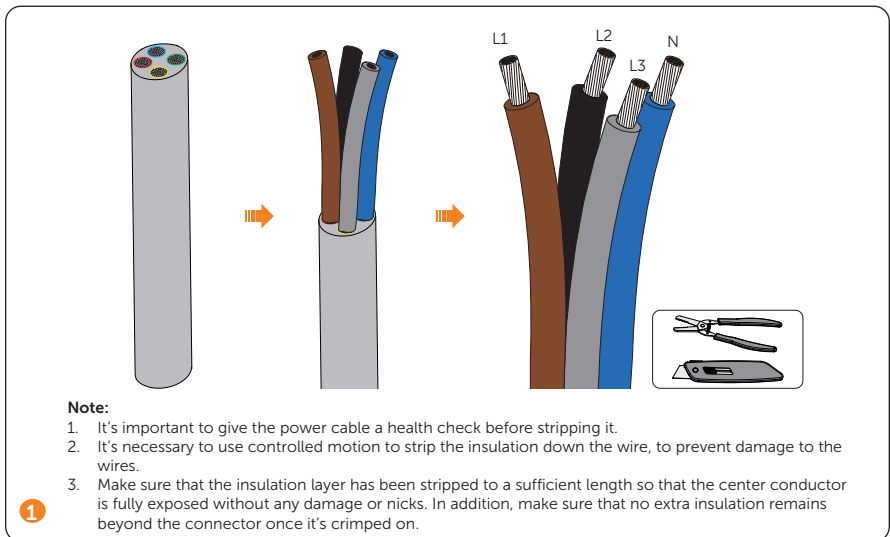

Note:

1. It's important to give the power cable a health check before stripping it.
2. It's necessary to use controlled motion to strip the insulation down the wire, to prevent damage to the wires.
3. Make sure that the insulation layer has been stripped to a sufficient length so that the center conductor is fully exposed without any damage or nicks. In addition, make sure that no extra insulation remains beyond the connector once it's crimped on.

1

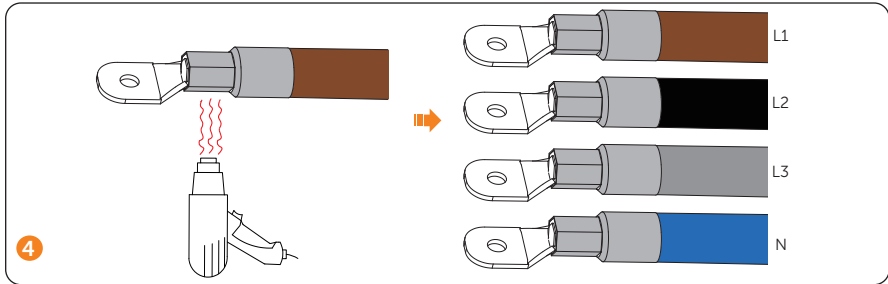
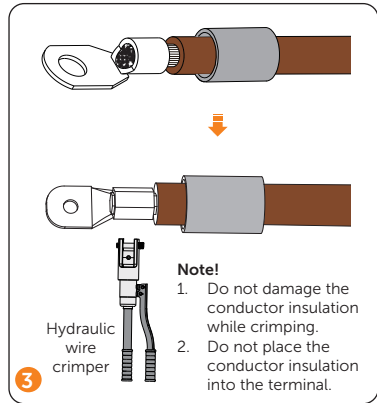
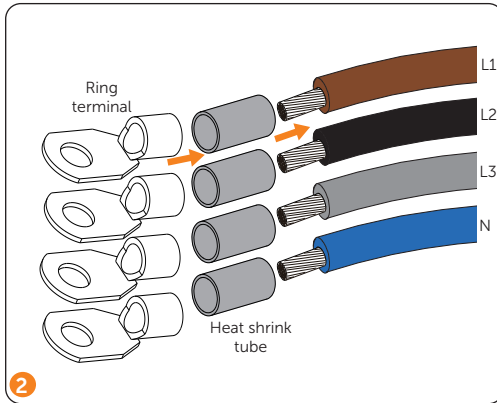

Grounding Connection

NOTICE!

- The cabinet offers 2 ports for grounding the cabinet at the left and right side. Select either port to perform grounding connection.

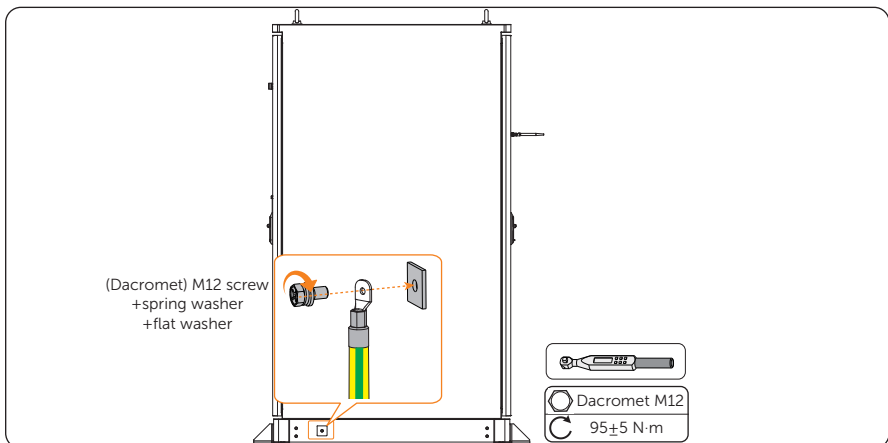

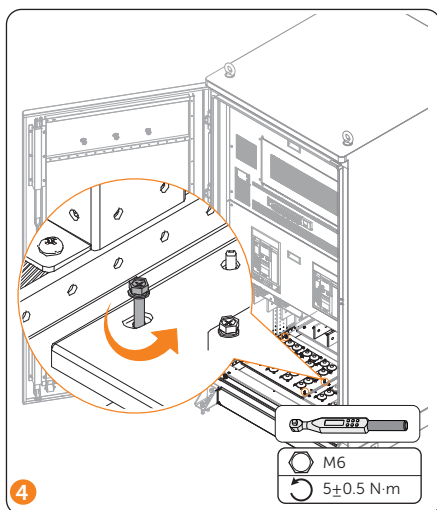
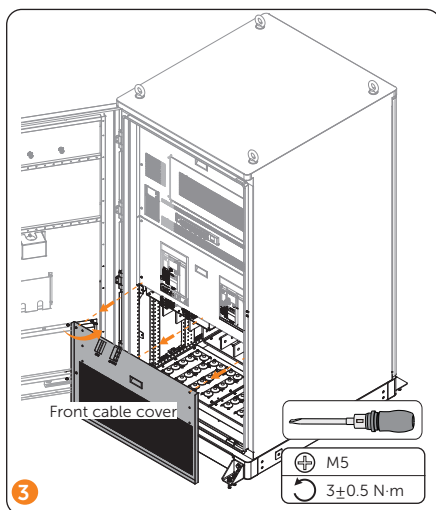
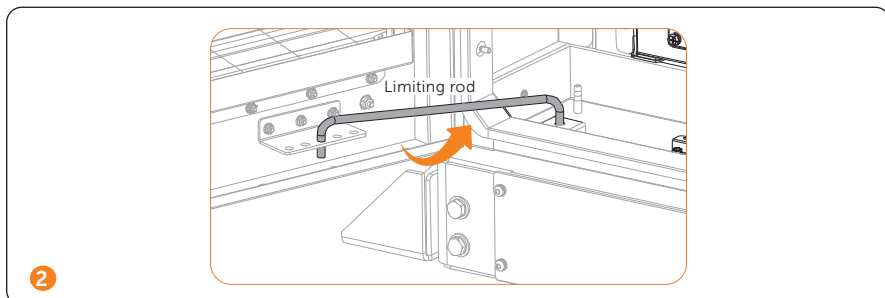
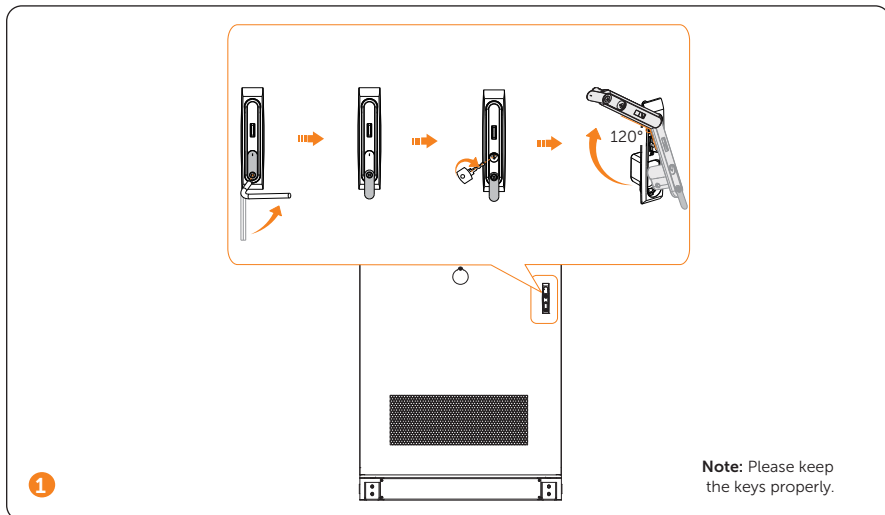

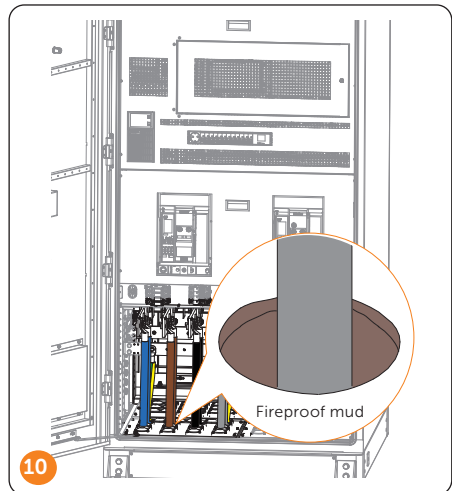
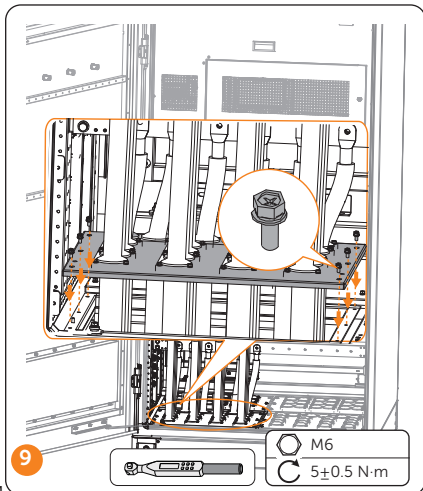
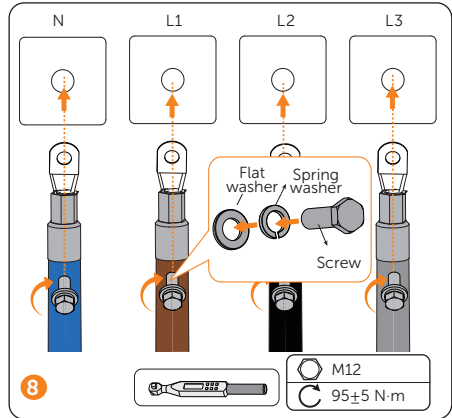
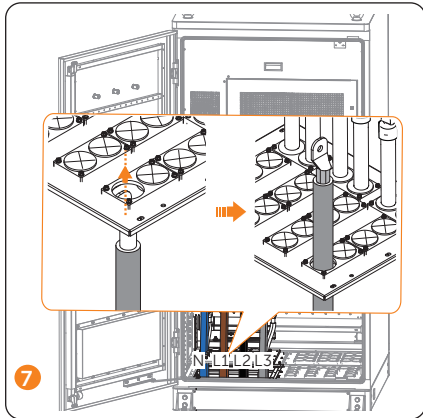
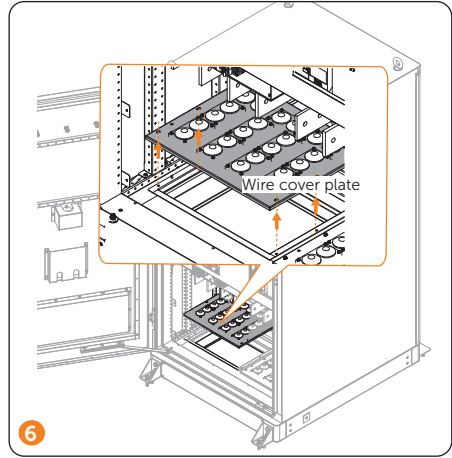
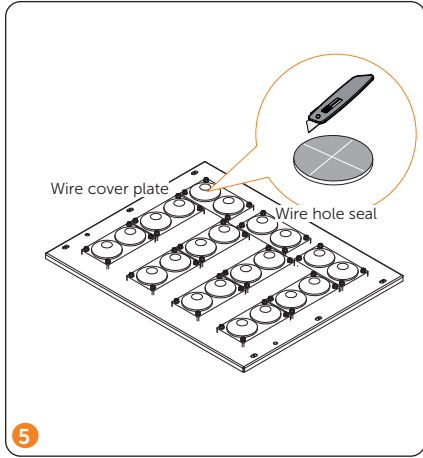

Load Connection

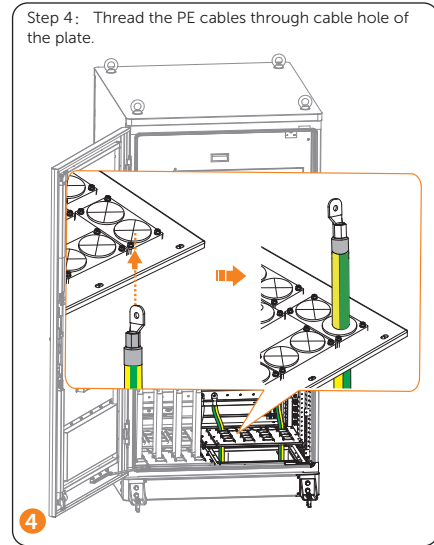
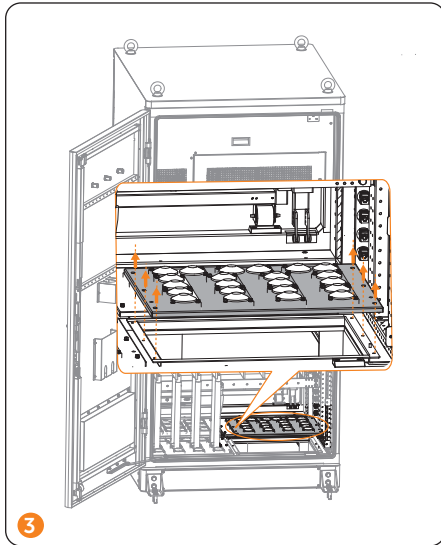
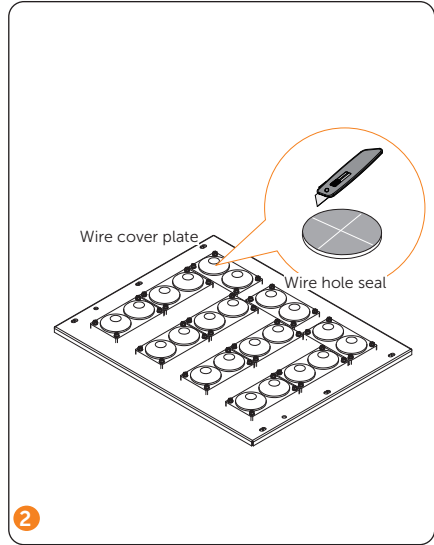
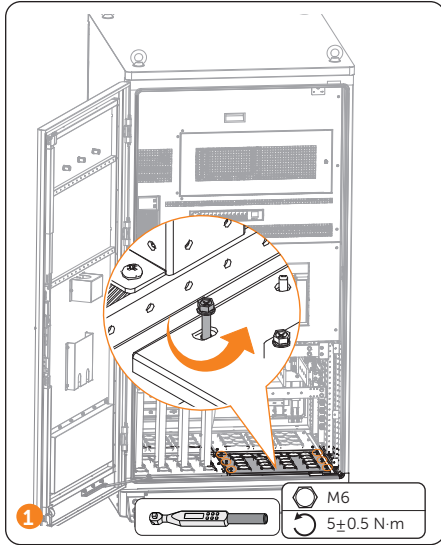

Step 5: Thread the power cables through cable hole of the plate.

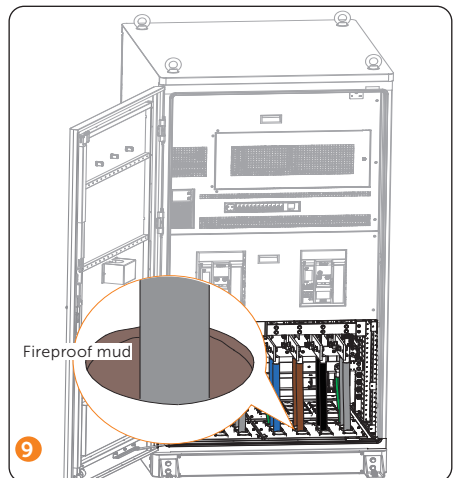
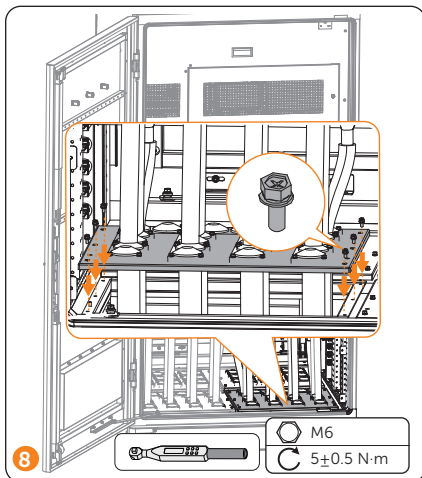
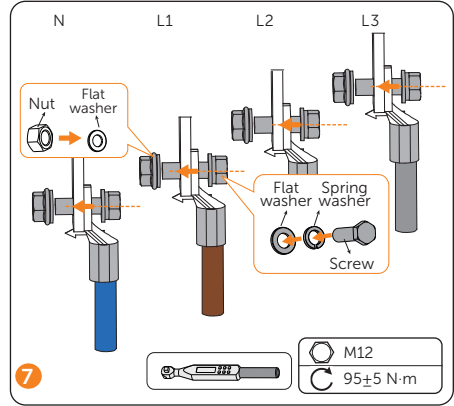
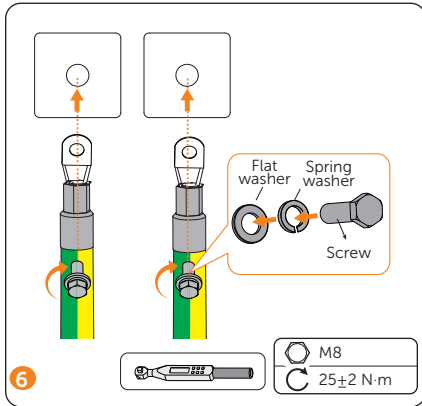
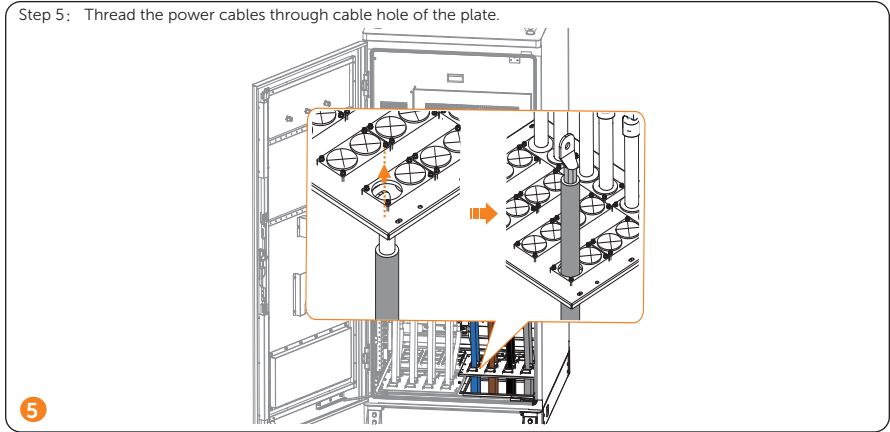

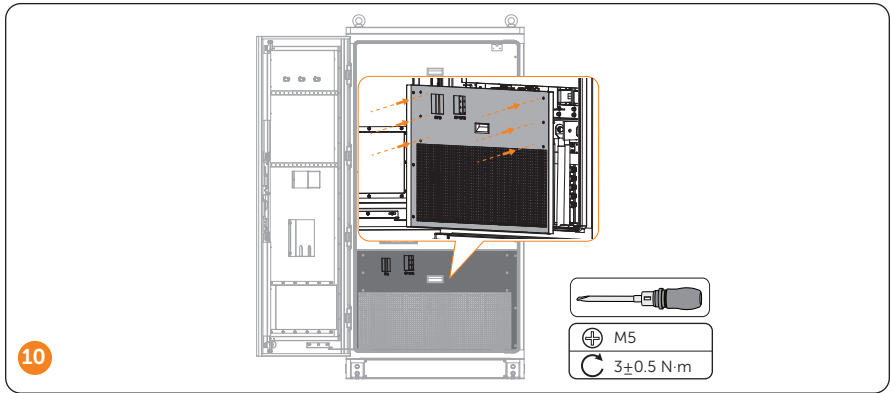

10

PCS Connection

NOTICE!

- Two types of power cables are supported for PCS: 35mm² and 70mm². The wiring steps of the two types of cables only differ in the number of wires connected to each terminal. The identical wiring steps use 50mm² power cables for example.
- For 70mm² power cable, totally 6 groups of 4-core copper cables are required, with each PCS terminal connected to a wire; For 35mm² power cable, totally 10 groups of 4-core copper cables are required, with each of 4 PCS terminals connected to two wires, and each of 2 PCS terminals connected to one wire. Users can decide how do they distribute the connection terminal and wires.

No.	Rated Power of PCS	Cable Specification Required	Quantity
1	≤60 kW	35 mm ² cooper wire	10 groups
2	60–125 kW	70 mm ² cooper wire	6 groups

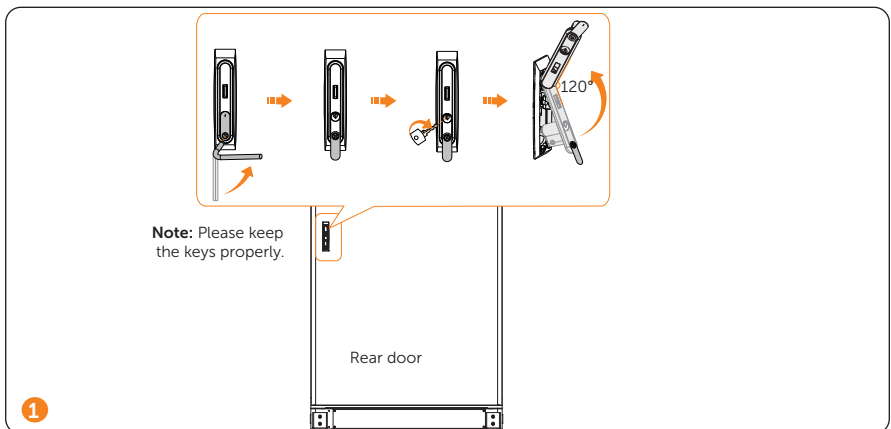

1

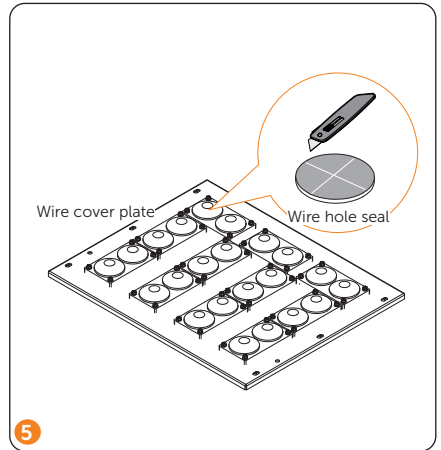
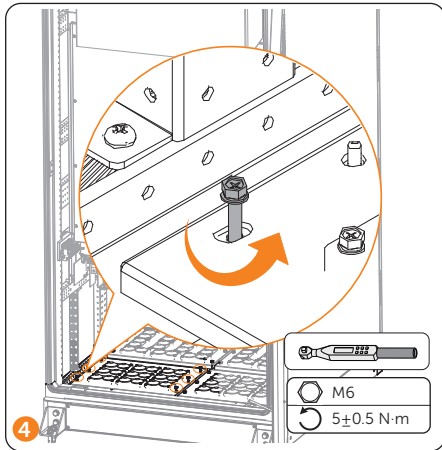
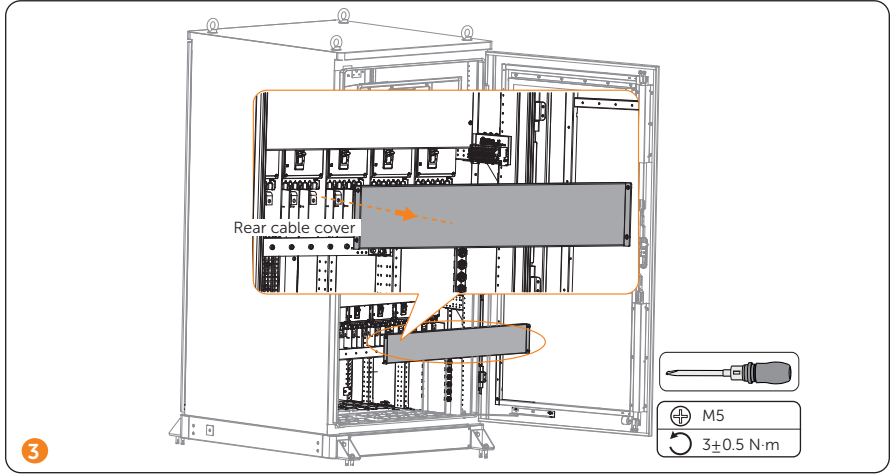
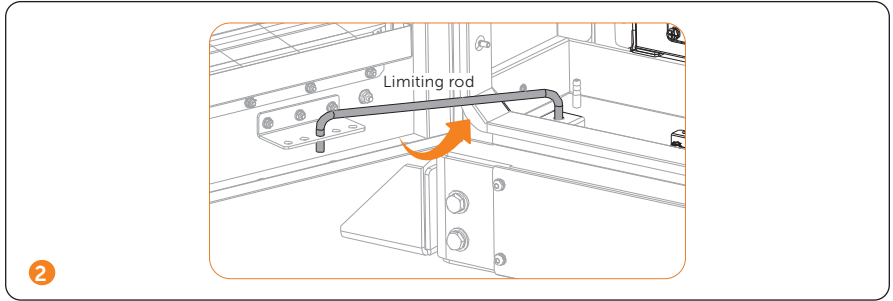

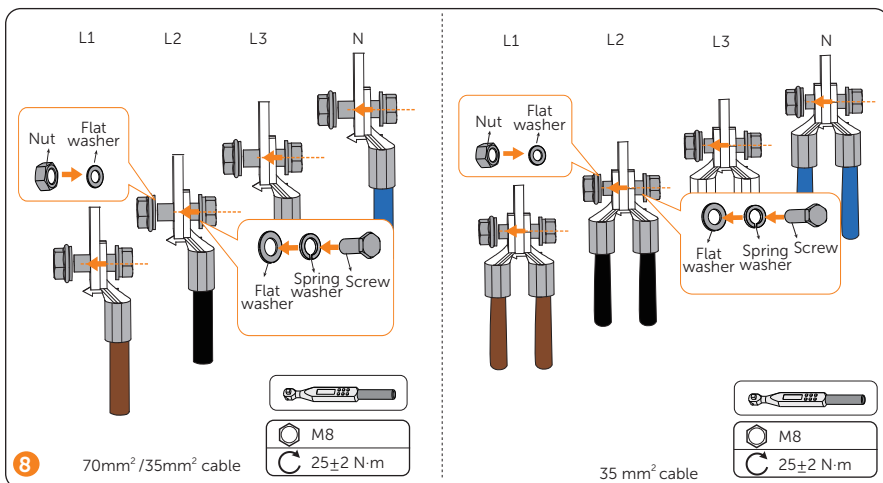
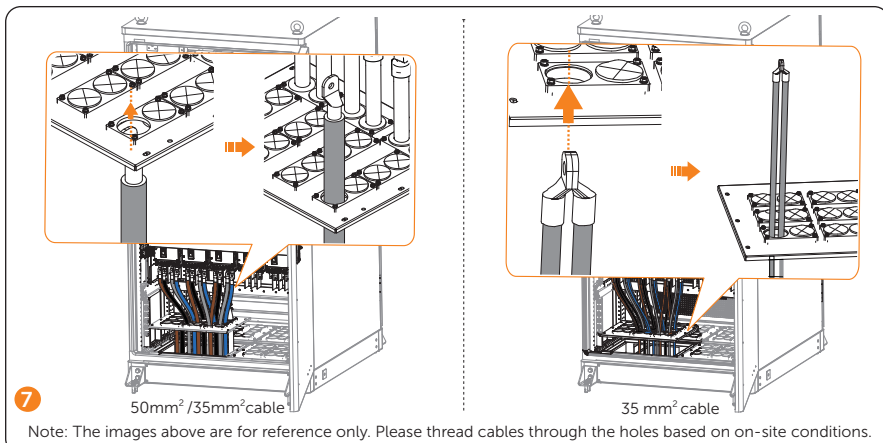
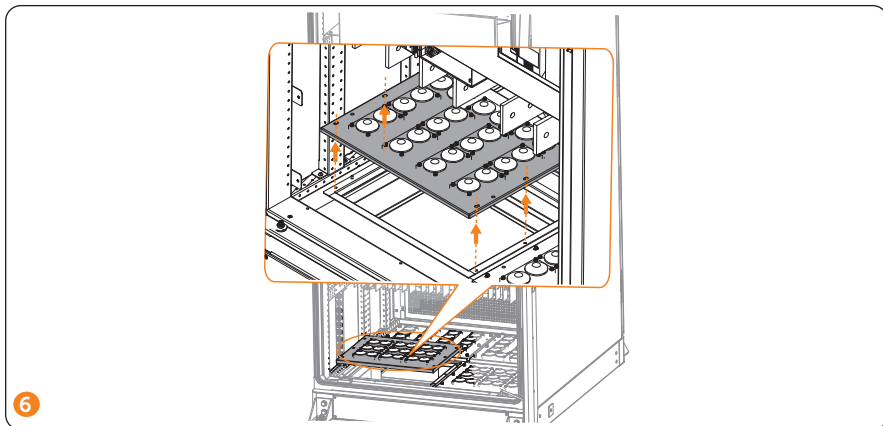

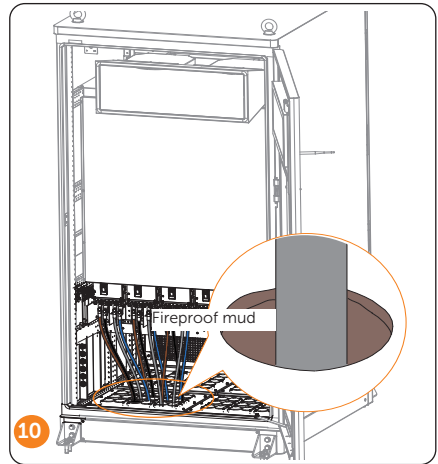
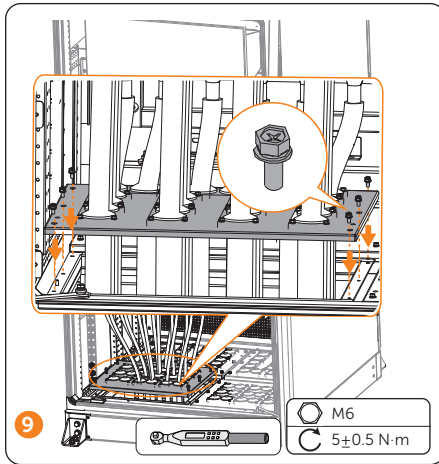

Follow the instructions from step 2 to step 10 to connect the power cables for PCS at the right side.

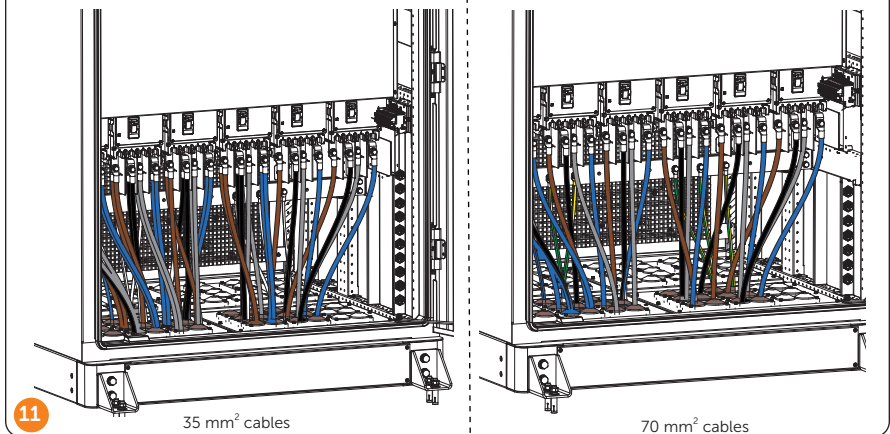

Network Connection

The cabinet offers 22 network ports in total, 11 on each side of the cabinet rear.

NOTICE!

- The 11 network ports at the left side are for data exchange with the energy storage cabinets, and the other 11 ports at the right side are for communication control.

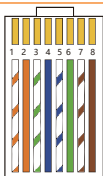

PIN No.	Color	PIN No.	Color
1	Orange-White	5	Blue-White
2	Orange	6	Green
3	Green-White	7	Brown-White
4	Blue	8	Brown

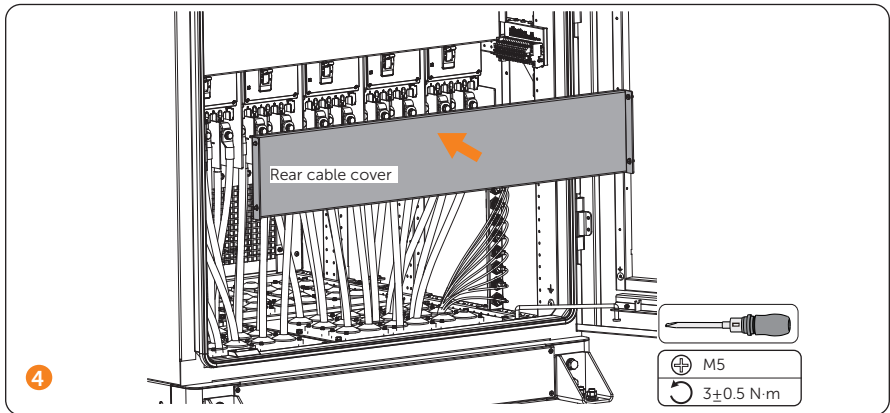
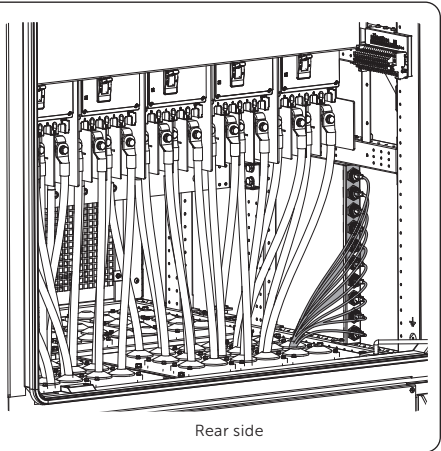
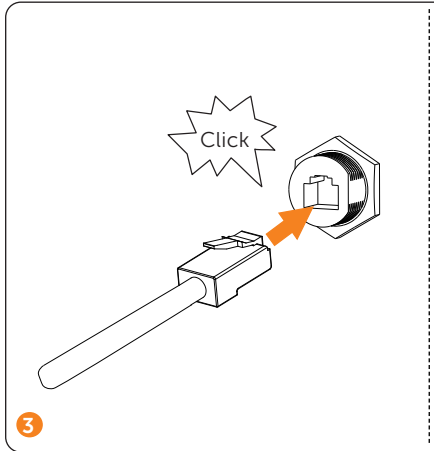
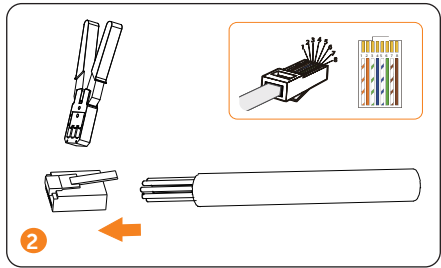
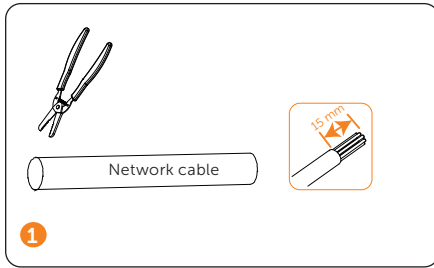

EMS Connection

EMS adapter terminal block is on the left of the cabinet rear.

No.	Marking	Description	No.	Marking	Description
1	EMS: A1	Connected to SolaX MEGA and Forth PV inverters	10	EMS: A6	
2	EMS: B1		11	EMS: B6	Reserved
3	EMS: G1		12	EMS: G6	
4	EMS: A4	Connected to diesel generator through communication mode	13	EMS: A8	
5	EMS: B4		14	EMS: B8	Connected to grid-connected meter
6	EMS: G4		15	EMS: G8	
7	EMS: A5	Connected to third-party PV inverters	16	EMS: DO8+	
8	EMS: B5		17	EMS: DO8-	Connected to diesel generator through dry contact
9	EMS: G5		18	EMS: DI6	
			19	EMS: DI COM	

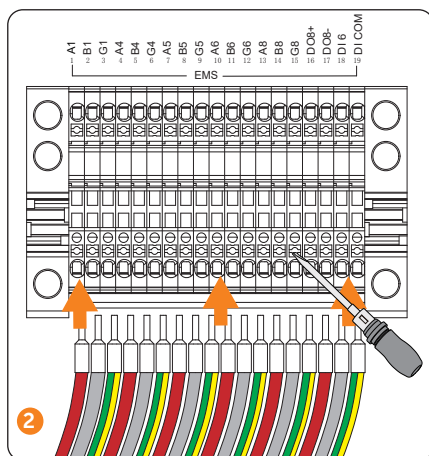
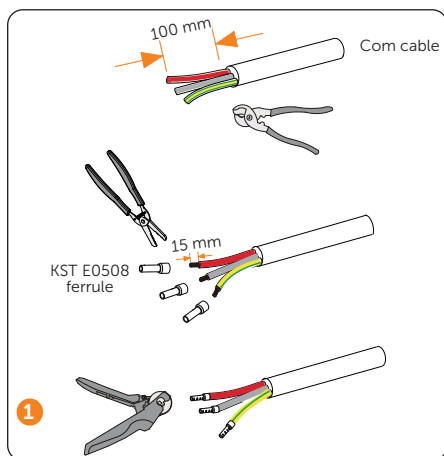

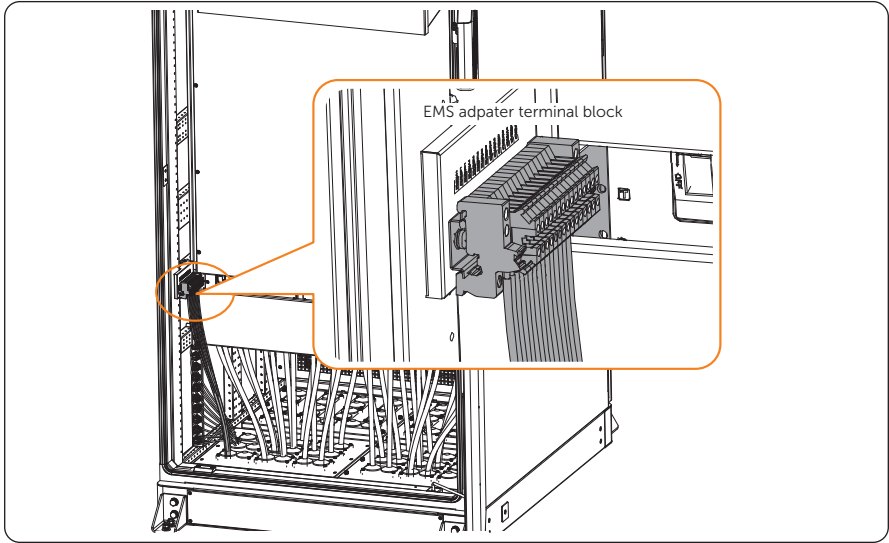

Control Board Connection

Control board adapter terminal block is on the right of the cabinet rear.

No.	Marking	Description	No.	Marking	Description
1	GND_SELV		11	DO_1	
2	ARM_PARA_A		12	DO_2	Reserved
3	ARM_PARA_B		13	PCS_DO_1	
4	PARA_CANH	For parallel connection with TRENE systems (excluding TRENE-P100B215I)	14	PCS_DO_2	
5	PARA_CANL		15	R1+	
6	PARA_50HZ		16	R2+	For resistor connection when connected to AELIO systems
7	PARA_SYNC		17	R1-	
8	GND_SELV		18	R2-	
9	PCS_485A	For parallel connection with AELIO systems and TRENE-P100B215I			
10	PCS_485B				

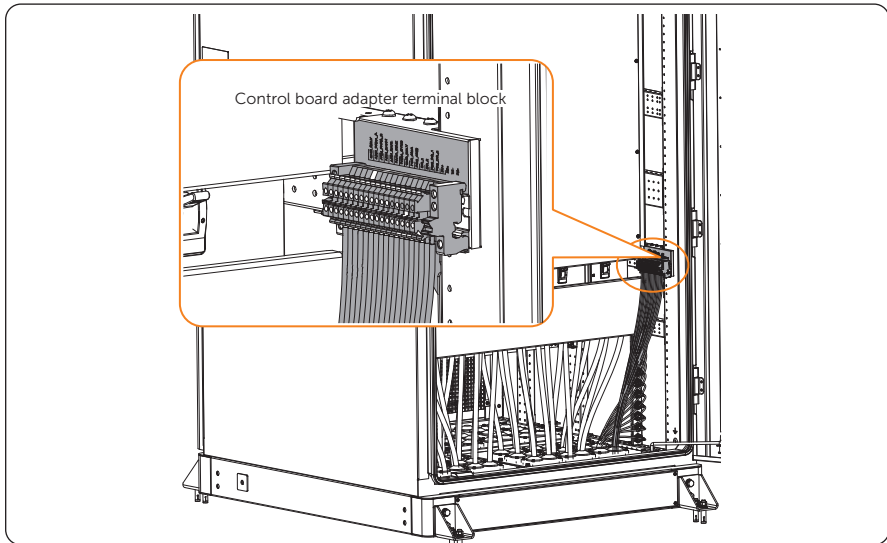
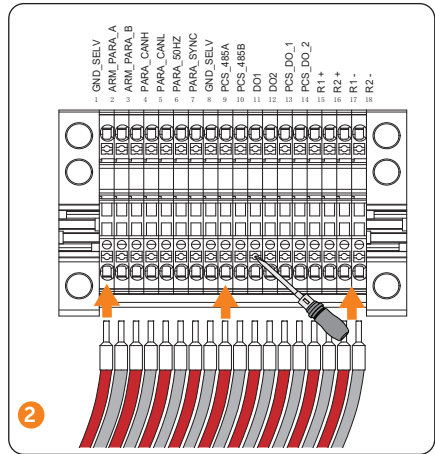
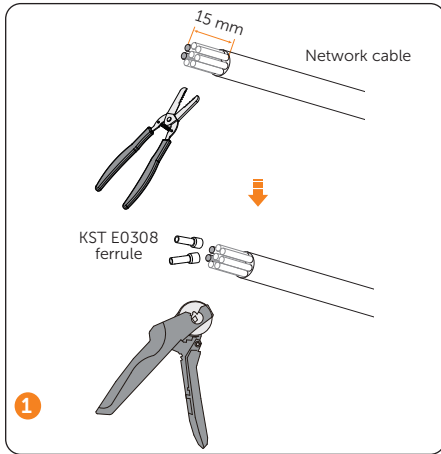

System Power-on

The location of modules for powering on the system are as follows.

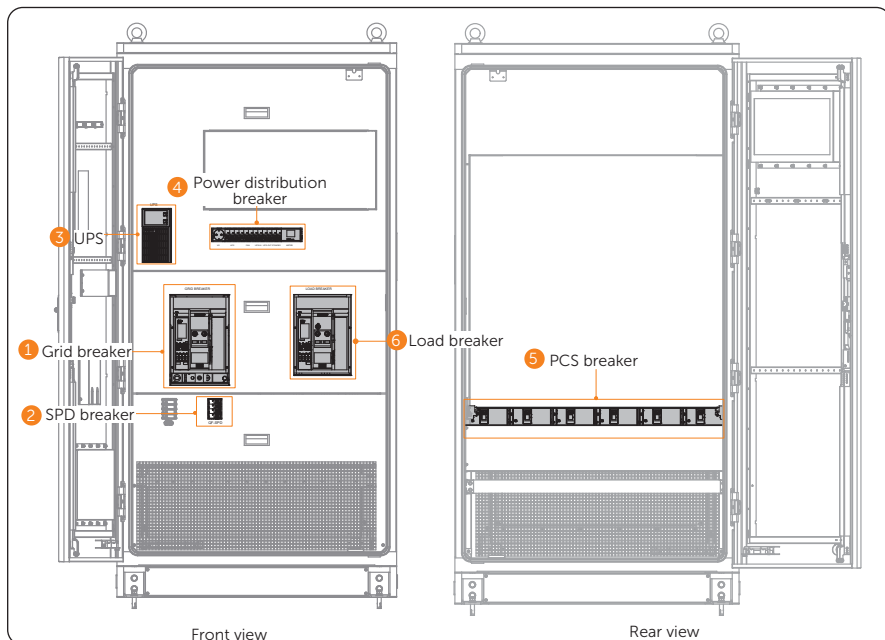

Strictly follow the steps to power on the system.

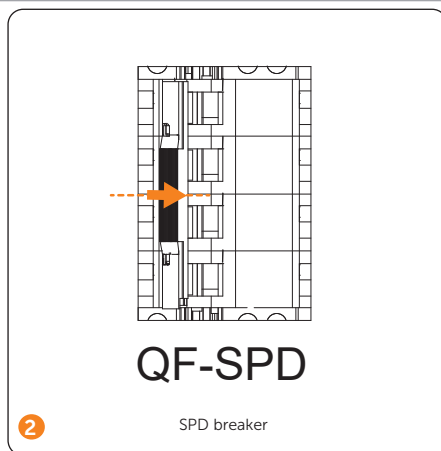
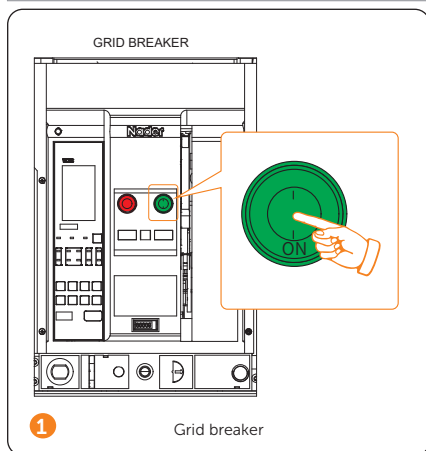

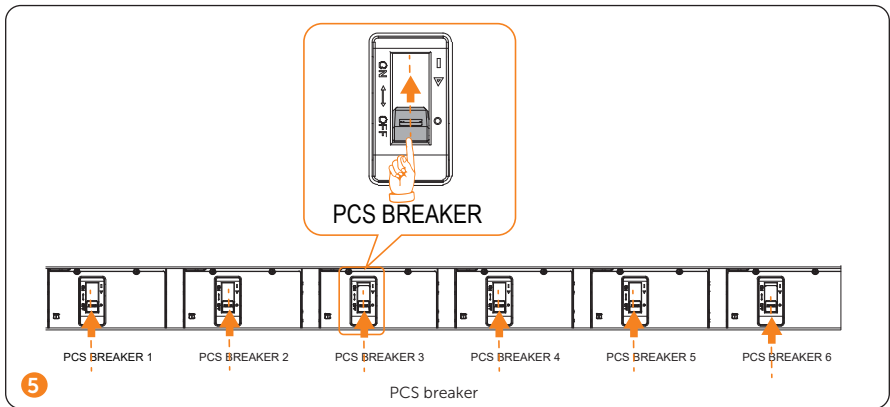
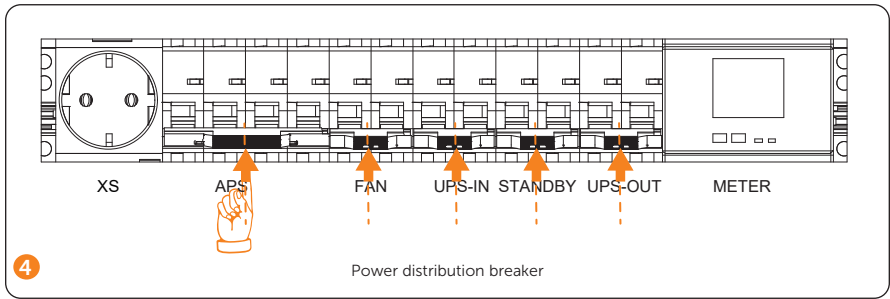
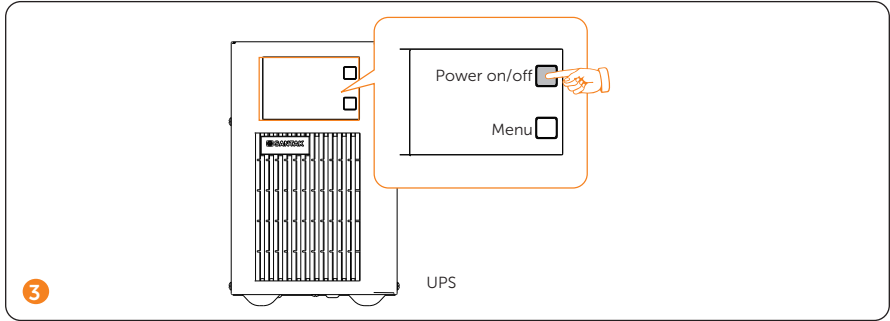

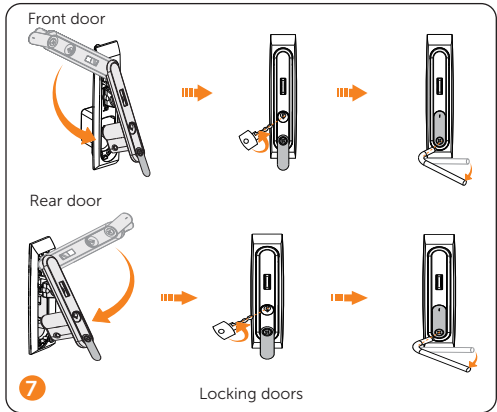
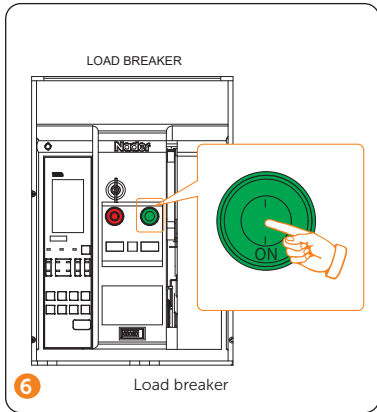

NOTICE!

- Make sure you have locked the doors well after normally powering on the system.

System Power-off

There are two circumstances: 1. Normal power off; 2. Emergency power off.

Normal Power Off

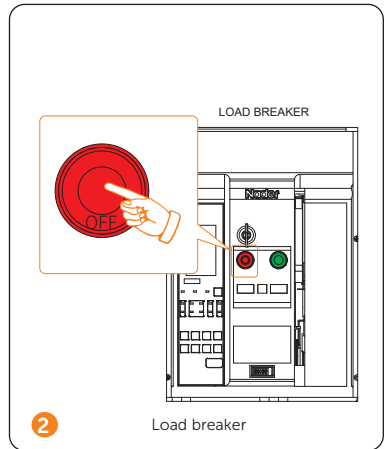
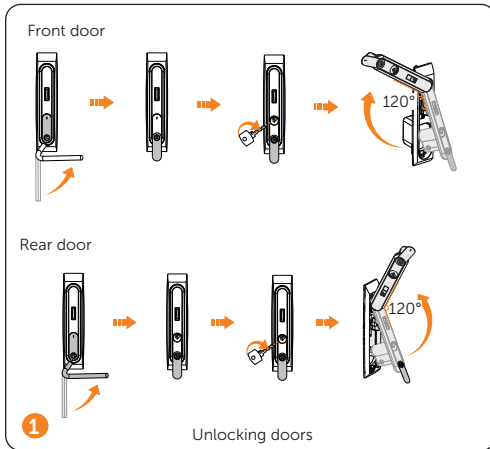

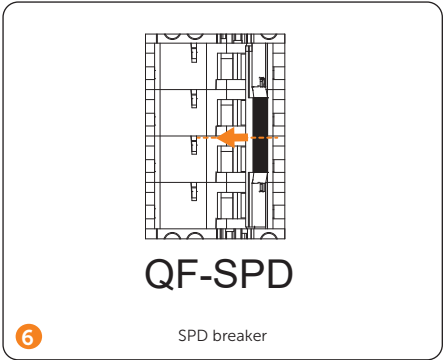
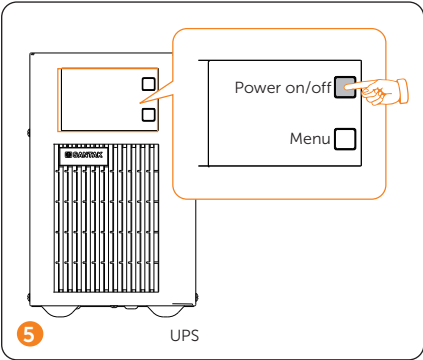
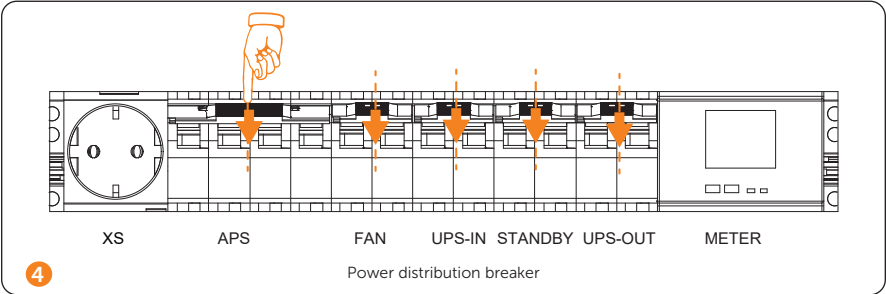
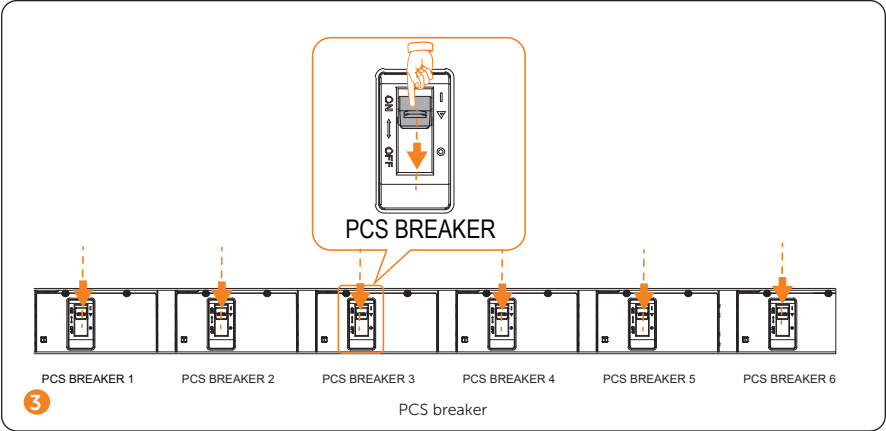

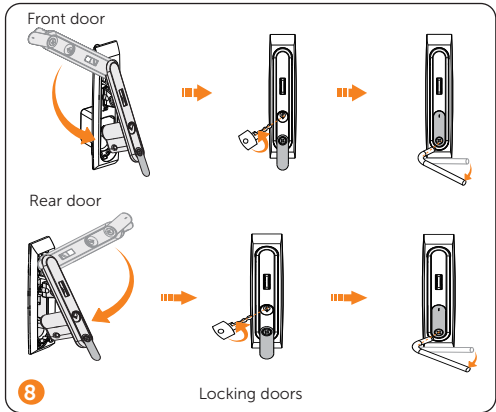
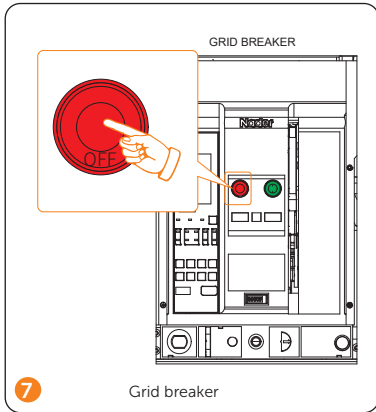

NOTICE!

- Make sure you have locked the doors well after normally powering on the system.

Emergency Power Off

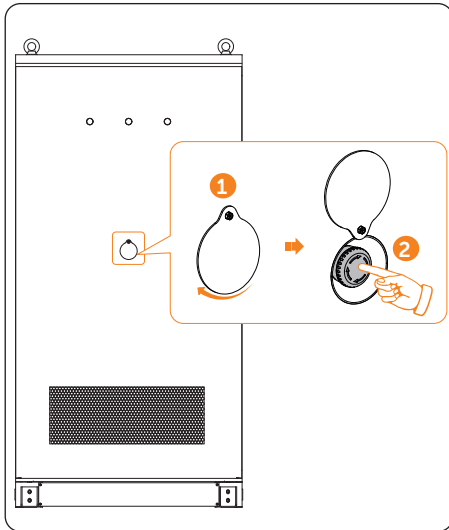

WARNING!





Do not press the emergency stop button unless in an emergency.

Note!
If the emergency stop button has ever been pressed down, it must be reset before you power the system next time. The resetting procedure is as follows:

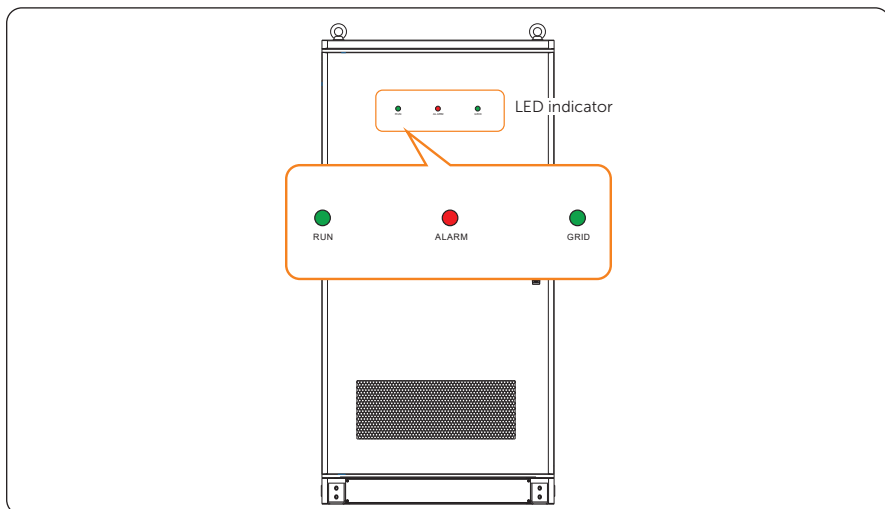
1. Rotate up the cover;
2. Rotate the button according to the arrow direction shown on the button, and then the button will spring back to its original position.

LED Indicators



Indicator	Status	Description
Run	Solid green 	Normal running
Alarm	Solid red 	System exception
Grid	Solid green 	On-grid running
	Off 	Off-grid running



Technical Data

Model	X3-PCAB-750kW-A
Rated AC voltage	3 / N / PE, 230 / 400 V
Rated AC frequency	50 / 60 Hz
Rated AC power	750 kW
Max. AC power	825 kVA
Max. AC current	1195.7 a. c A
Rated short circuit current	40 kA
Transfer between on/off grid	200 ms
Power limit (Grid)	Yes
PCS breaker	250 A × 6
Grid breaker	1600 A
Load breaker	1600 A
SPD	Type II
Ingress protection	IP55
Operating ambient temperature range	-30 °C ~ 55°C
Dimension (W × H × D)	1050 × 2100 × 1200 mm
Relative humidity (RH)	0 to 95%
Operating altitude	≤3000 m
Weight	≤800 kg
Communication	Ethernet/RS485/CAN/DI
Certificates and approvals	IEC61439-1, IEC61439-2, IEC 61000, IEC 60730

Contact Information





UNITED KINGDOM

 Unit C-D Riversdale House, Riversdale Road, Atherstone, CV9 1FA
 +44 (0) 2476 586 998
 service.uk@solaxpower.com





TURKEY

 Fevzi Çakmak mah. asım cd. no 88 A Karatay / Konya / Türkiye
 service.tr@solaxpower.com



USA

 3780 Kilroy Airport Way, Suite 200, Long Beach, CA, US 90806
 +1 (408) 690 9464
 info@solaxpower.com





POLAND

 WARSAW AL. JANA P. II 27. POST
 +48 662 430 292
 service.pl@solaxpower.com



ITALY

 +39 011 19800998
 support@solaxpower.it





PAKISTAN

 service.pk@solaxpower.com







AUSTRALIA

 21 Nicholas Dr, Dandenong South VIC 3175
 +61 1300 476 529
 service@solaxpower.com.au







GERMANY

 Am Tullnaupark 8, 90402 Nürnberg, Germany
 +49 (0) 6142 4091 664
 service.eu@solaxpower.com
 service.dach@solaxpower.com





NETHERLANDS

 Twekkeler-Es 15 7547 ST Enschede
 +31 (0) 8527 37932
 service.eu@solaxpower.com
 service.bnl@solaxpower.com





SPAIN

 +34 9373 79607
 tecnico@solaxpower.com



BRAZIL

 +55 (34) 9667 0319
 info@solaxpower.com



SOUTH AFRICA

 service.za@solaxpower.com

Warranty Registration Form



For Customer (Compulsory)

Name Country

Phone Number Email

Address

State Zip Code

Product Serial Number

Date of Commissioning

Installation Company Name

Installer Name Electrician License No.

For Installer

Module (If Any)

Module Brand

Module Size(W)

Number of String Number of Panel Per String

Battery (If Any)

Battery Type

Brand

Number of Battery Attached

Date of Delivery Signature

Please visit our warranty website: <https://www.solaxcloud.com/#/warranty> or use your mobile phone to scan the QR code to complete the online warranty registration.



For more detailed warranty terms, please visit SolaX official website: www.solaxpower.com to check it.





SolaX Power Network Technology (Zhejiang) Co., Ltd.

Add.: No. 278, Shizhu Road, Chengnan Sub-district, Tonglu County,
Hangzhou, Zhejiang, China
E-mail: info@solaxpower.com

